

COMPONENT SPECIFICATION

SERIES NAME Metallized Polypropylene DC Link Film Capacitors
SERIES CODE 91

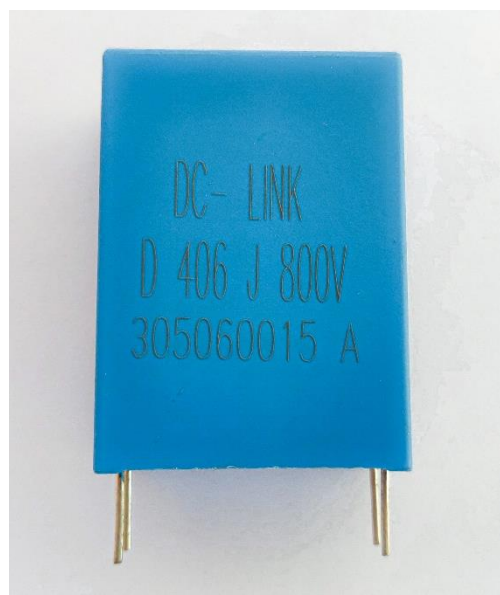
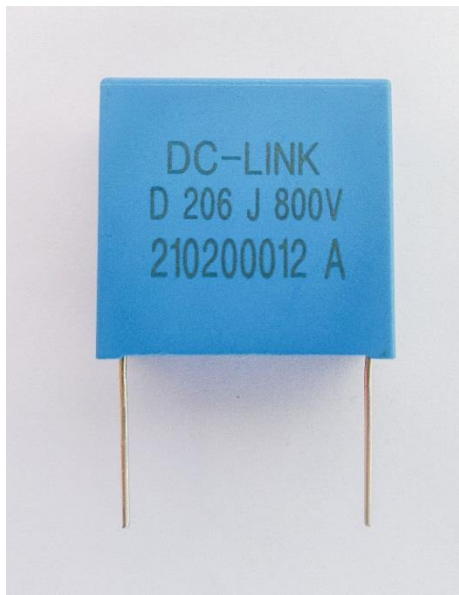

GIVEN BY: DEKI ELECTRONICS LTD

DEKI ELECTRONICS LTD

B-20, SECTOR-58, NOIDA 201301

Tel: +91 120 2585457/58 • Fax: +91 120 2585289 • Email: rd@dekielectronics.com

Metallized Polypropylene DC Link Film Capacitors

Series Code 91

Part Number Description

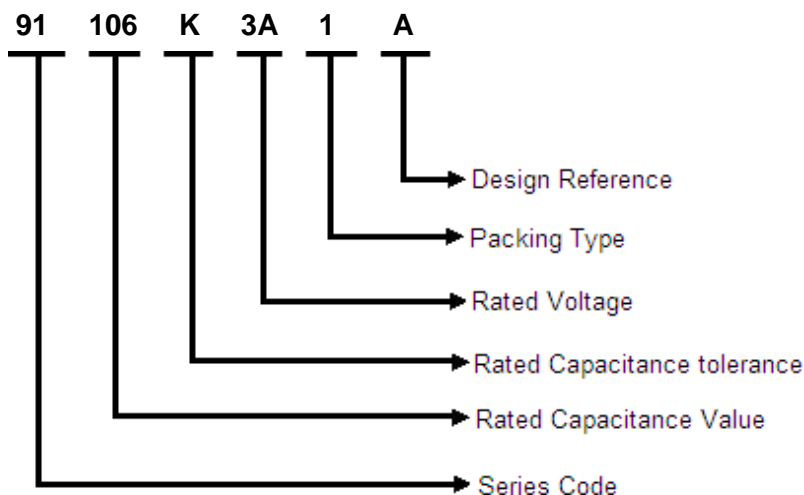

Rated Capacitance

Three-digit (224) indicate rated capacitance in Pico Farad (First two digits indicate value & third digit indicates number of zeroes to be suffixed to first two digits).

For example:

103 = 10 × 10 ³	= 10000 pF	= 10 nF	= 0.01 μF
104 = 10 × 10 ⁴	= 100000 pF	= 100 nF	= 0.1 μF
105 = 10 × 10 ⁵	= 1000000 pF	= 1000 nF	= 1 μF
106 = 10 × 10 ⁶	= 10000000 pF	= 10000 nF	= 10 μF

Capacitance Tolerance

In 3rd group of the part number-

F = ±1%, G = ±2%, H = ±2.5%, I = ±3.5%, J = ±5%, K = ±10%, L = ±15%, M = ±20%, N=±40%

Rated Voltage

In 4th group of the part number, one numeric digit and one letter (Ex.-2A) indicate DC voltage rating while two numeric digits (Ex.06) indicate AC voltage rating.

Rated Voltage Codification

For DC Rated Voltage													
A		B		C		D		E		F		G	
1A	10	1B	12.5	1C	16	1D	20	1E	25	1F	30	1G	40
2A	100	2B	125	2C	160	2D	200	2E	250	2F	300	2G	400
3A	1000	3B	1250	3C	1600	3D	2000	3E	2500	3F	3000	3G	4000
H		I		J		K		L		M		N	
1H	50	1I	45	1J	63	1K	70	1L	80	1M	85	1N	90
2H	500	2I	450	2J	630	2K	700	2L	800	2M	850	2N	900
3H	5000	3I	4500	3J	6300	3K	7000	3L	8000	3M	8500	3N	9000
O		P		Q		R		S		U		V	
1O	110	1P	120	1Q	57.5	1R	15	1S	17	1U	130	1V	60
2O	1100	2P	1200	2Q	575	2R	150	2S	170	2U	1300	2V	600
3O	11000	3P	12000	3Q	5750	3R	1500	3S	1700	3U	13000	3V	6000
For AC Rated Voltage													
01	02	03	04	05	06	07	08	09	10	11	12	13	14
190 VAC	250 VAC	275 VAC	305 VAC	310 VAC	440 VAC	500 VAC	600 VAC	700 VAC	63 VAC	230 VAC	330 VAC	400 VAC	450 VAC

Metallized Polypropylene DC Link Film Capacitors

Series Code 91

Packing Type

- 1: Bulk packing (original pitch)
- 2: Bulk packing (after forming & cutting)
- 3: Ammo packing (after forming & taping)
- 4: Bulk packing (after forming in original pitch without cut)
- 5: Bulk packing (after formed & without cut)
- 6: Ammo packing (Straight lead)
- 7: Bulk packing (Straight lead cut)
- 8: Reel packing (Straight lead)

Reference Data

Capacitance	1 μ F to 210 μ F
Capacitance Tolerance	\pm 5%
Rated DC Voltage	450Vdc to 1500Vdc
Climatic testing class according to IEC 60068-1	40/70/56
Reference standard	IEC 61071
Maximum application temperature	100°C
Rated temperature	85°C
Dielectric	Polypropylene
Electrodes	Metallized
Construction	Mono
Encapsulation	Encased in flame retardant box filled with resin
Leads	Tinned wire

Compatibility to RoHS



Marking Code Example (20 μ F/ \pm 5%/800Vdc)

DC – LINK
D 206 J 800V
201020121 A

Dimensions Description

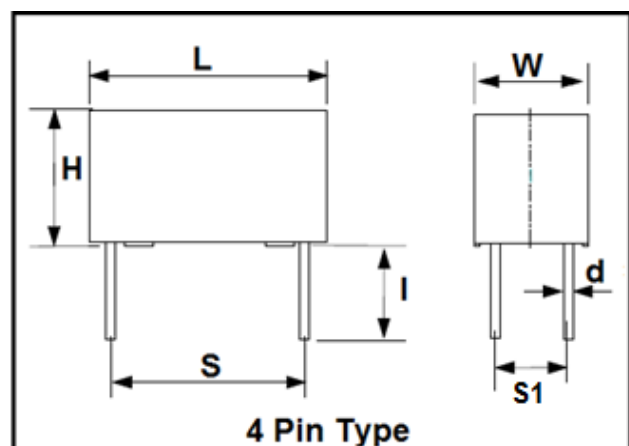
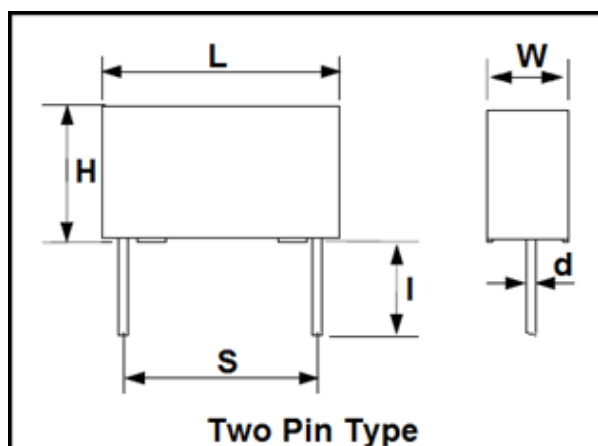

Metallized Polypropylene DC Link Film Capacitors

Series Code 91



Rated Cap. (µF)	Dimensions (mm)						dV/dt (V/µs)	I _{pk} (A)	I _{rms} (10 kHz) (A)	ESR (10 kHz) (mΩ)	ESL (nH)	Part Number
	L (±1.0)	H (±1.0)	W (±1.0)	S (±1.0)	S1	d						
450 Vdc												
5	31	23	13	27.5±1.0	-	0.8±0.1	5.5±1.0	-	-	-	-	91 505 K 2I 7 A
5.6	31.5	20	11	27.5	-	0.8	15 Min.	10	54	4.5	13.1	91 565 J 2I 1 A
10	31.5	25	13	27.5	-	0.8	15 Min.	10	96	6.5	8.1	91 106 J 2I 1 A
12.5	31.5	28	14	27.5	-	0.8	15 Min.	10	122	7.5	6.8	91 126 J 2I 1 A
15	31.5	29	19	27.5	-	0.8	15 Min.	10	147	8.5	6	91 156 J 2I 1 A
20	32.0	37	22	27.5	-	0.8	5.0±1.0	10	200	10	5.5	91 206 J 2I 7 A
25	31.5	37	22	27.5	-	0.8	15 Min.	10	245	11.5	4.5	91 256 J 2I 1 A
40	42	40	20	37.5	10.2	1	15 Min.	7	262	13.5	3.5	91 406 J 2I 1 B
50	42	37	28	37.5	10.2	1	15 Min.	7	332	16	2.8	91 506 J 2I 1 B
70	42	45	30	37.5	20.3	1	15 Min.	7	464	20.5	2.1	91 706 J 2I 1 E
100	57.5	45	30	52.5	20.3	1.2	15 Min.	4	442	19	3	91 107 J 2I 1 C
130	57.5	50	35	52.5	20.3	1.2	15 Min.	4	581	23	2.4	91 137 J 2I 1 C
500 Vdc												
5.6	31.5	20	11	27.5	-	0.8	15 Min.	10	54	4.5	13.1	91 565 J 2H 1 A
10	31.5	25	13	27.5	-	0.8	15 Min.	10	96	6.5	8.1	91 106 J 2H 1 A
12.5	31.5	28	14	27.5	-	0.8	15 Min.	10	122	7.5	6.8	91 126 J 2H 1 A
15	31.5	29	19	27.5	-	0.8	15 Min.	10	147	8.5	6	91 156 J 2H 1 A
25	31.5	37	22	27.5	-	0.8	15 Min.	10	245	11.5	4.5	91 256 J 2H 1 A
40	42	40	20	37.5	10.2	1	15 Min.	7	262	13.5	3.5	91 406 J 2H 1 B
50	42	37	28	37.5	10.2	1	15 Min.	7	332	16	2.8	91 506 J 2H 1 B
70	42	45	30	37.5	20.3	1	15 Min.	7	464	20.5	2.1	91 706 J 2H 1 E
90	42	50	35	37.5	20.3	1	15 Min.	7	585	26	1.5	91 906 J 2H 1 E
100	57.5	45	30	52.5±1.0	20.3±0.5	1.2±0.1	5	20	200	20.36	3	91 107 J 2H 7 A
130	57.5	50	35	52.5	20.3	1.2	15 Min.	4	581	23	2.4	91 137 J 2H 1 C
170	57.5	56	45	52.5	20.3	1.2	15 Min.	4	780	29.5	1.8	91 177 J 2H 1 C
210	57.5	65	45	52.5	20.3	1.2	15 Min.	4	840	35.5	1.4	91 217 J 2H 1 C
600 Vdc												
3.3	31.5	20	11	27.5	-	0.8	15 Min.	13	41	4	17	91 335 J 2V 1 A
5.0	31.0	23.5	14	27.5	-	0.8	15 Min.	72	360	4.65	23.47	91 505 K 2V 1 A
5.0	31.0	23.5	14	27.5	-	0.8	6 Min.	35	175	4.72	21.97	91 505 K 2V 1 B
5.6	31.5	25	13	27.5	-	0.8	15 Min.	13	71	6	10.7	91 565 J 2V 1 A
7	31.5	28	14	27.5	-	0.8	15 Min.	13	88	7	9	91 705 J 2V 1 A
10	31.5	29	19	27.5	-	0.8	15 Min.	13	127	8.5	6.8	91 106 J 2V 1 A
12	31	33	18	27.5±0.6	-	1.0±0.1	5.5±1.0	-	-	-	-	91 126 K 2V 7 A
15	31.5	37	22	27.5	-	0.8	15 Min.	13	190	10.5	5.3	91 156 J 2V 1 A
20	42	40	20	37.5	10.2	1	15 Min.	9	172	11	5.3	91 206 J 2V 1 B
30	42	37	28	37.5	10.2	1	15 Min.	9	255	14	3.6	91 306 J 2V 1 B
40	42	45	30	37.5	20.3	1	15 Min.	9	344	18	2.8	91 406 J 2V 1 E
55	57.5	45	30	52.5	20.3	1.2	15 Min.	6	319	16.5	4.1	91 556 J 2V 1 C
75	57.5	50	35	52.5	20.3	1.2	15 Min.	6	435	20.5	3.1	91 756 J 2V 1 C
630 Vdc												
12	31	33	18	27.5±0.6	-	1.0±0.1	5.5±1.0	-	-	-	-	91 126 K 2J 7 A
650 Vdc												
3.3	31.5	20	11	27.5	-	0.8	15 Min.	13	41	4	17	91 335 J 2W 1 A
5.6	31.5	25	13	27.5	-	0.8	15 Min.	13	71	6	10.7	91 565 J 2W 1 A

Metallized Polypropylene DC Link Film Capacitors

Series Code 91



Rated Cap. (µF)	Dimensions (mm)						dV/dt (V/µs)	I _{pk} (A)	I _{rms} (10 kHz) (A)	ESR (10 kHz) (mΩ)	ESL (nH)	Part Number	
	L (±1.0)	H (±1.0)	W (±1.0)	S	S1	d							l
650 Vdc													
7	31.5	28	14	27.5	-	0.8	15 Min.	13	88	7	9	26	91 705 J 2W 1 A
10	31.5	29	19	27.5	-	0.8	15 Min.	13	127	8.5	6.8	26	91 106 J 2W 1 A
15	31.5	37	22	27.5	-	0.8	15 Min.	13	190	10.5	5.3	28	91 156 J 2W 1 A
20	42	40	20	37.5	10.2	1	15 Min.	9	172	11	5.3	30	91 206 J 2W 1 B
30	42	37	28	37.5	10.2	1	15 Min.	9	255	14	3.6	30	91 306 J 2W 1 B
40	42	45	30	37.5	20.3	1	15 Min.	9	344	18	2.8	30	91 406 J 2W 1 E
50	42	50	35	37.5	20.3	1	15 Min.	9	430	22.5	2	35	91 506 J 2W 1 E
55	57.5	45	30	52.5	20.3	1.2	15 Min.	6	319	16.5	4.1	35	91 556 J 2W 1 C
75	57.5	50	35	52.5	20.3	1.2	15 Min.	6	435	20.5	3.1	35	91 756 J 2W 1 C
110	57.5	56	45	52.5	20.3	1.2	15 Min.	6	625	27	2.2	41	91 117 J 2W 1 C
130	57.5	65	45	52.5	20.3	1.2	15 Min.	6	754	32	1.7	45	91 137 J 2W 1 C
700 Vdc													
2.7	31.5	20	11	27.5	-	0.8	15 Min.	19	51	4	18.3	25	91 275 J 2K 1 A
4	31.5	25	13	27.5	-	0.8	15 Min.	19	77	5.5	12.9	25	91 405 J 2K 1 A
5	31.5	28	14	27.5	-	0.8	15 Min.	19	96	6	10.7	26	91 505 J 2K 1 A
8	31.5	29	19	27.5	-	0.8	15 Min.	19	154	8	7.3	26	91 805 J 2K 1 A
12.5	31.5	37	22	27.5	-	0.8	15 Min.	19	241	10	5.5	28	91 126 J 2K 1 A
15	42	40	20	37.5	5.1	1	15 Min.	13	196	10	6.2	30	91 156 J 2K 1 F
15	42	40	20	37.5	10.2	1	15 Min.	13	196	10	6.2	30	91 156 J 2K 1 B
20	42	37	28	37.5	10.2	1	15 Min.	13	262	12.5	4.7	30	91 206 J 2K 1 B
30	42	45	30	37.5	20.3	1	15 Min.	13	389	16.5	3.2	30	91 306 J 2K 1 E
45	57.5	45	30	52.5	20.3	1.2	15 Min.	9	389	16	4.4	35	91 456 J 2K 1 C
55	57.5	50	35	52.5	20.3	1.2	15 Min.	9	485	19	3.6	35	91 556 J 2K 1 C
60	57.5	50	35	52.5	20.3	1.2	15 Min.	9	530	19.5	3.4	35	91 606 J 2K 1 C
800 Vdc													
2.7	31.5	20	11	27.5	-	0.8	15 Min.	19	51	4	18.3	25	91 275 J 2L 1 A
4	31.5	25	13	27.5	-	0.8	15 Min.	19	77	5.5	12.9	25	91 405 J 2L 1 A
5	31.5	25	14	27.5±0.5	-	0.8±0.05	5.5±0.5	40	200	5.5	15.5	-	91 505 K 2L 7 A
5	31.5	28	14	27.5	-	0.8	15 Min.	19	96	6	10.7	26	91 505 J 2L 1 A
8	31	30	17.2	27.5±0.5	-	0.8±0.05	6.0±1.0	45	200	8.75	8	-	91 805 K 2L 7 A
8	31.5	29	19	27.5	-	0.8	15 Min.	19	154	8	7.3	26	91 805 J 2L 1 A
12	32	37	22	27.5	-	1±0.05	15 Min.	-	-	-	-	-	91 126 J 2L 1 A
15	42	40	20	37.5	5.1	1	15 Min.	13	196	10	6.2	30	91 156 J 2L 1 F
15	42	40	20	37.5	10.2	1	15 Min.	13	196	10	6.2	30	91 156 J 2L 1 B
20	41.5	39	19.5	37.5±0.6	-	1.2±0.05	15 Min.	-	-	-	-	-	91 206 J 2L 1 A
20	42	37	28	37.5	10.2	1	15 Min.	13	262	12.5	4.7	30	91 206 J 2L 1 B
30	42	45	30	37.5	20.3	1	15 Min.	13	389	16.5	3.2	30	91 306 J 2L 1 E
40	42	50	35	37.5	20.3	1	15 Min.	13	524	21.5	2.2	35	91 406 J 2L 1 E
45	57.5	45	30	52.5	20.3	1.2	15 Min.	9	389	16	4.4	35	91 456 J 2L 1 C
55	57.5	50	35	52.5	20.3	1.2	15 Min.	9	485	19	3.6	35	91 556 J 2L 1 C
60	57	50	35	52.5±0.6	20.3±1.0	1.2±0.1	6.0±1.0	-	-	-	-	-	91 606 J 2L 7 Q
65	57	60	35	52.5±0.6	20.3±1.0	1.2±0.1	5.5±1.0	-	-	-	-	-	91 656 K 2L 7 A

Metallized Polypropylene DC Link Film Capacitors

Series Code 91



Rated Cap. (µF)	Dimensions (mm)						dV/dt (V/µs)	I _{pk} (A)	I _{rms} (10 kHz) (A)	ESR (10 kHz) (mΩ)	ESL (nH)	Part Number	
	L (±1.0)	H (±1.0)	W (±1.0)	S	S1	d							l
800 Vdc													
85	57.5	56	45	52.5	20.3	1.2	15 Min.	9	728	25.5	2.5	41	91 856 J 2L 1 C
100	57.5	65	45	52.5	20.3	1.2	15 Min.	9	883	30.5	1.9	45	91 107 J 2L 1 C
900 Vdc													
1	31	23.5	14	27.5±1.0	-	1.0±0.1	5.5±1.0	-	180	5	32.5	-	91 105 K 2N 7 A
1.5	31.5	20	11	27.5	-	0.8	15 Min.	24	36	3.5	26.3	25	91 155 J 2N 1 A
2.7	31.5	25	13	27.5	-	0.8	15 Min.	24	65	5	15.3	25	91 275 J 2N 1 A
3.3	31.5	28	14	27.5	-	0.8	15 Min.	24	79	5.5	12.9	26	91 335 J 2N 1 A
5	31.5	29	19	27.5	-	0.8	15 Min.	24	120	7	9.1	26	91 505 J 2N 1 A
8	31.5	37	22	27.5	10.2	0.8	15 Min.	24	193	9.5	6.6	28	91 805 J 2N 1 D
12	42	40	20	37.5	10.2	1	15 Min.	16	190	10	6.3	30	91 126 J 2N 1 B
14	42	37	28	37.5	20.3	1	15 Min.	16	229	11.5	5.4	30	91 146 J 2N 1 E
20	42	45	30	37.5	20.3	1	15 Min.	16	321	15	3.9	30	91 206 J 2N 1 E
30	57.5	45	30	52.5	20.3	1.2	15 Min.	11	324	15	5.2	35	91 306 J 2N 1 C
40	57.5	50	35	52.5	20.3	1.2	15 Min.	11	428	18	4	35	91 406 J 2N 1 C
1000 Vdc													
10	42	40	20	37.5±1.0	-	1.2±0.1	4.0±0.5	60	200	9.9	14	-	91 106 J 3A 7 A
14	42.5	37	28	37.5±0.6	10.2±1.0	1.0±0.1	5.5±1.0	-	-	-	-	-	91 146 K 3A 7 A
65	57	65	45	52.5±0.5	20.3±0.5	1.2±0.05	6±1.0	25	200	27	4	-	91 656 J 3A 7 A
1100 Vdc													
1.5	31	20	11	27.5±0.5	-	0.8±0.05	6±1.0	-	200	2.75	-	-	91 155 J 2O 7 A
2.2	31	24.5	15	27.5±0.5	-	0.8±0.05	15 Min.	-	200	4.25	27	-	91 225 K 2O 1 A
2.7	31.5	25	13	27.5	-	0.8	15 Min.	24	65	5	15.3	25	91 275 J 2O 1 A
3.3	31.5	28	14	27.5	-	0.8	15 Min.	24	79	5.5	12.9	26	91 335 J 2O 1 A
5	31.5	29	19	27.5	-	0.8	15 Min.	24	120	7	9.1	26	91 505 J 2O 1 A
8	31.5	37	22	27.5	-	0.8	15 Min.	24	193	9.5	6.6	28	91 805 J 2O 1 A
12	42	40	20	37.5	10.2	1	15 Min.	16	190	10	6.3	30	91 126 J 2O 1 B
14	42	37	28	37.5	10.2	1	15 Min.	16	229	11.5	5.4	30	91 146 J 2O 1 B
20	42	45	30	37.5±0.6	-	1.2±0.1	5.5±1.0	-	-	-	-	-	91 206 K 2O 7 A
25	42	50	35	37.5	20.3	1	15 Min.	16	409	19	2.8	35	91 256 J 2O 1 E
30	57.5	45	30	52.5	20.3	1.2	15 Min.	11	324	15	5.2	35	91 306 J 2O 1 C
40	57	50	35	52.5±0.5	20.3±0.5	1±0.05	5.5±0.5	25	200	21	5	-	91 406 J 2O 7 A
55	57.5	56	45	52.5	20.3	1.2	15 Min.	11	595	24.5	2.6	41	91 556 J 2O 1 C
65	57.5	65	45	52.5	20.3	1.2	15 Min.	11	717	28	2.3	45	91 656 J 2O 1 C
1300 Vdc													
1	31.5	20	11	27.5	-	0.8	15 Min.	28	28	3	33.1	25	91 105 J 2U 1 A
1.8	31.5	25	13	27.5	-	0.8	15 Min.	29	52	4.5	19.1	25	91 185 J 2U 1 A
2.2	31.5	28	14	27.5	-	0.8	15 Min.	29	63	5	16	26	91 225 J 2U 1 A
3.3	31.5	29	19	27.5	-	0.8	15 Min.	29	95	6.5	11.2	26	91 335 J 2U 1 A
5	31.5	37	22	27.5	-	0.8	15 Min.	29	145	8.5	8.2	28	91 505 J 2U 1 A
8	42	40	20	37.5	10.2	1	15 Min.	20	157	9	7.9	30	91 805 J 2U 1 B

Metallized Polypropylene DC Link Film Capacitors

Series Code 91

Rated Cap. (μF)	L (±1.0)	H (±1.0)	W (±1.0)	Dimensions (mm)		d	l	dV/dt (V/μs)	I _{pk} (A)	I _{rms} (10 kHz) (A)	ESR (10 kHz) (mΩ)	ESL (nH)	Part Number
10	42	37	28	37.5	10.2	1	15 Min.	20	196	11	6.3	30	91 106 J 2U 1 B
12	42	45	30	37.5	20.3	1	15 Min.	20	235	13	5.3	30	91 126 J 2U 1 E
1300 Vdc													
18	42	50	35	37.5	20.3	1	15 Min.	19	350	18	3.2	35	91 186 J 2U 1 E
20	57.5	45	30	52.5	20.3	1.2	15 Min.	13	262	13	6.5	35	91 206 J 2U 1 C
25	57.5	50	35	52.5	20.3	1.2	15 Min.	13	331	16	5.2	35	91 256 J 2U 1 C
27	57.5	50	35	52.5	20.3	1.2	15 Min.	13	354	16.5	4.9	35	91 276 J 2U 1 C
38	57.5	56	45	52.5	20.3	1.2	15 Min.	13	498	22.5	3.1	41	91 386 J 2U 1 C
45	57.5	65	45	52.5	20.3	1.2	15 Min.	13	596	26	2.7	45	91 456 J 2U 1 C
1500 Vdc													
1	31.5	20	11	27.5	-	0.8	15 Min.	31	31	3.5	25.7	24	91 105 J 3R 1 A
1.5	31.5	25	13	27.5	-	0.8	15 Min.	31	49	4.5	17.7	25	91 155 J 3R 1 A
2	31.5	28	14	27.5	-	0.8	15 Min.	32	65	5.5	14.1	26	91 205 J 3R 1 A
3	31.5	29	19	27.5	-	0.8	15 Min.	32	95	7	9.7	26	91 305 J 3R 1 A
4.5	31.5	37	22	27.5	-	0.8	15 Min.	33	148	9	7.3	28	91 455 J 3R 1 A
6	42	40	20	37.5	10.2	1	15 Min.	22	132	9	8	30	91 605 J 3R 1 B
8	42	37	28	37.5	10.2	1	15 Min.	22	176	11	6	30	91 805 J 3R 1 B
12	42	45	30	37.5	20.3	1	15 Min.	22	256	14.5	4.1	33	91 126 J 3R 1 E
15	42	50	35	37.5	20.3	1	15 Min.	22	326	17.5	3.5	35	91 156 J 3R 1 E
17	57.5	45	30	52.5	20.3	1.2	15 Min.	14	236	13.5	5.9	35	91 176 J 3R 1 C
22	57.5	50	35	52.5	20.3	1.2	15 Min.	14	308	17	4.6	38	91 226 J 3R 1 C
32	57.5	56	45	52.5	20.3	1.2	15 Min.	14	460	22	3.4	41	91 326 J 3R 1 C
40	57.5	65	45	52.5	20.3	1.2	15 Min.	14	562	25	2.8	45	91 406 J 3R 1 C

Specific Data

Description

Value

Maximum tangent of loss angle (Tanδ)	≤ 0.0035 at 1 kHz
Voltage proof test between leads	1.5 times of the rated voltage for 10 second
Insulation resistance or time constant (R _{IS} x C) between leads at 100 Vdc	≥ 10000 second

Temperature Derating Graph

For temperature between 85°C and 100°C a derating factor of 1.25% per °C on the rated voltage V_R has to be applied.

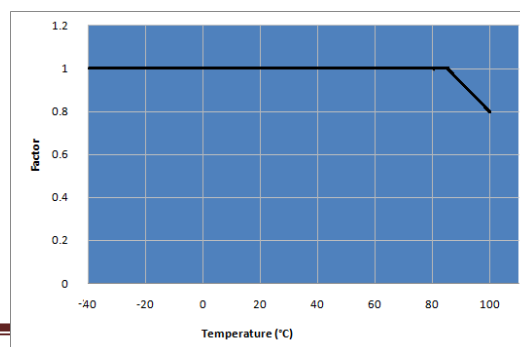

Power Dissipation and Maximum Component Temperature Rise

After applying the A.C voltage to the capacitor with certain frequency, we can measure the hot spot temperature of the capacitor. From that we can calculate ΔT .

ΔT = hot spot temperature - ambient temperature

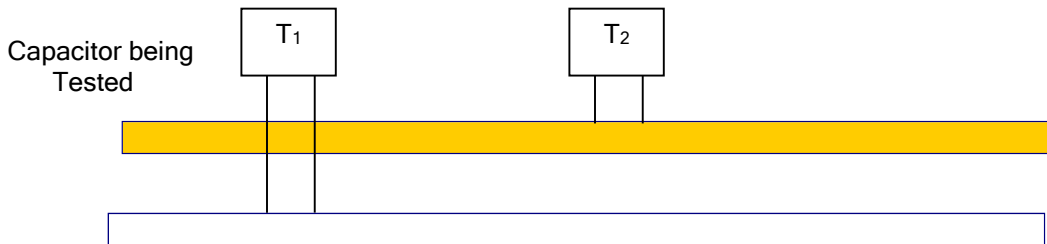

T₁ is the capacitor under test (Connected in the circuit)

T₂ is capacitor which has no connection

Distance between T₁ and T₂ should be about 50mm and 100mm from other components. To avoid radiation or convection, the capacitor should be tested in a wind-free box. The capacitor under test is separated by polystyrene.

$$\Delta T_{\max} = T_1 - T_2$$

at one frequency level the ΔT_{\max} reach 10°C. That is the frequency which we have to start frequency derating.

Disclaimer

All our capacitors are designed, manufactured and tested to specifications. We strictly adhere to standards in procurement of materials, in the laid down manufacturing processes and consistently apply stringent process controls and testing parameters. This ensures that our capacitors always perform to the offered specifications.

Appropriateness of use in a specific circuit and fitness to a particular application however needs to be verified and its reliability through expected lifetime is required to be validated by the customer. Deki's responsibility is limited to ensuring that the capacitor performs as claimed in the specification/ data sheets provided by Deki. Deki specifically disclaims any implied warranties of fitness for any particular purpose. Liability, in any case is limited to the price paid for the capacitors.

Metallized Polypropylene DC Link Film Capacitors
Series Code 91



Metallized Polypropylene DC Link Film Capacitors

Series Code 91



Metallized Polypropylene DC Link Film Capacitors

Series Code 91



Metallized Polypropylene DC Link Film Capacitors

Series Code 91

