

COMPONENT SPECIFICATION

SERIES NAME Metallized Polypropylene Film Capacitors
(MPP-Box Type)
SERIES CODE 27



GIVEN BY: DEKI ELECTRONICS LTD

DEKI ELECTRONICS LTD

B-19 & 20, SECTOR-58, NOIDA 201301

Tel: +91 120 2585457/58 • Fax: +91 120 2585289 • Email: rd@dekielectronics.com

Metallized Polypropylene Film Capacitors

Box Type • Series Code 27

Part Number Description

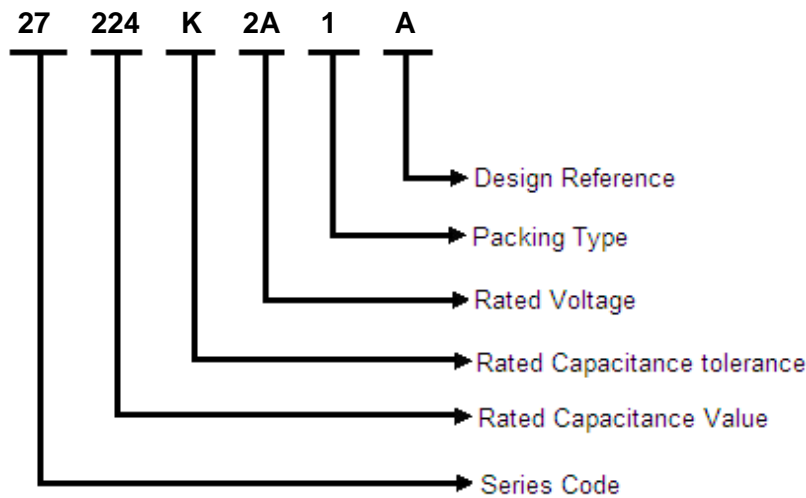

Rated Capacitance

Three-digit (224) indicate rated capacitance in Pico Farad (First two digits indicate value & third digit indicates number of zeroes to be suffixed to first two digits).

For example:

103 = 10 × 10 ³	= 10000 pF	= 10 nF	= 0.01 μF
104 = 10 × 10 ⁴	= 100000 pF	= 100 nF	= 0.1 μF
105 = 10 × 10 ⁵	= 1000000 pF	= 1000 nF	= 1 μF
106 = 10 × 10 ⁶	= 10000000 pF	= 10000 nF	= 10 μF

Capacitance Tolerance

In 3rd group of the part number-

F = ±1%, G = ±2%, H = ±2.5%, I = ±3.5%, J = ±5%, K = ±10%, L = ±15%, M = ±20%, N = ±40%

Rated Voltage

In 4th group of the part number, one numeric digit and one letter (Ex.-2A) indicate DC voltage rating while two numeric digits (Ex.03) indicate AC voltage rating.

Rated Voltage Codification

For DC Rated Voltage													
A		B		C		D		E		F		G	
1A	10	1B	12.5	1C	16	1D	20	1E	25	1F	30	1G	40
2A	100	2B	125	2C	160	2D	200	2E	250	2F	300	2G	400
3A	1000	3B	1250	3C	1600	3D	2000	3E	2500	3F	3000	3G	4000
H		I		J		K		L		M		N	
1H	50	1I	45	1J	63	1K	70	1L	80	1M	85	1N	90
2H	500	2I	450	2J	630	2K	700	2L	800	2M	850	2N	900
3H	5000	3I	4500	3J	6300	3K	7000	3L	8000	3M	8500	3N	9000
O		P		Q		R		S		U		V	
1O	110	1P	120	1Q	1U	1U	15	1S	17	1U	130	1V	60
2O	1100	2P	1200	2Q	2U	2U	150	2S	170	2U	1300	2V	600
3O	11000	3P	12000	3Q	3U	3U	1500	3S	1700	3U	13000	3V	6000
For AC Rated Voltage													
01	02	03	04	05	06	07	08	09	10	11	12	13	14
190 VAC	250 VAC	275 VAC	305 VAC	310 VAC	440 VAC	500 VAC	600 VAC	700 VAC	63 VAC	230 VAC	330 VAC	400 VAC	450 VAC

Metallized Polypropylene Film Capacitors

Box Type • Series Code 27

Packing Type

- 1: Bulk packing (original pitch)
- 2: Bulk packing (after forming & cutting)
- 3: Ammo packing (after forming & taping)
- 4: Bulk packing (after forming in original pitch without cut)
- 5: Bulk packing (after formed & without cut)
- 6: Ammo packing (Straight lead)
- 7: Bulk packing (Straight lead cut)
- 8: Reel packing (Straight lead)

Reference Data

Capacitance	0.001 μ F to 4.7 μ F
Capacitance Tolerance	\pm 5% to \pm 10%
Rated Voltage	63 Vdc to 630 Vdc
Climatic testing class according to IEC 60068-1	40/100/56
Maximum application temperature	100°C
Rated temperature	85°C
Reference standards	IEC 60384-16
Dielectric	Polypropylene
Electrodes	Metallized
Construction	Mono
Encapsulation	Encased in flame retardant box filled with resin
Leads	Tinned wire
Marking on capacitor body	Type of capacitor, rated capacitance, rated tolerance, rated voltage and traceability code will be available on each and every capacitor. Example- D473K2J 9HMP023, or MPP D105K2J 902231234

Compatibility to RoHS



Dimensions Description

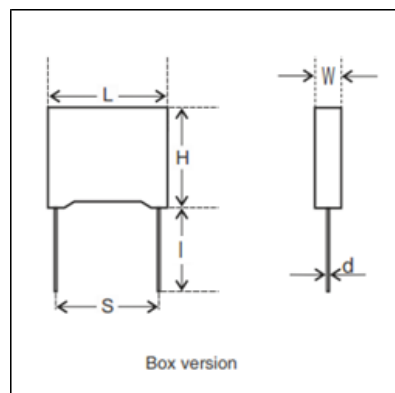

Metallized Polypropylene Film Capacitors

Box Type • Series Code 27

Rated Voltage	Rated Capacitance (μF)	Dimensions (mm)						dV/dt (V/μs)	Part Number
		W (±0.5)	H (±0.5)	L (±0.5)	d (±0.05)	S (±0.75)	I		
250Vdc/160Vac	0.033	4.0	9.0	13	0.6	10	15 Min.	280	27 333 +2E*^
	0.039	4.0	9.0	13	0.6	10	15 Min.	280	27 393 +2E*^
	0.047	4.0	9.0	13	0.6	10	15 Min.	280	27 473 +2E*^
	0.056	4.0	9.0	13	0.6	10	15 Min.	280	27 563 +2E*^
	0.068	4.0	9.0	13	0.6	10	15 Min.	280	27 683 +2E*^
	0.082	5.0	11.0	13	0.6	10	15 Min.	280	27 823 +2E*^
	0.1	5.0	11.0	13	0.6	10	15 Min.	280	27 104 +2E*^
	0.12	6.0	12.0	13	0.6	10	15 Min.	280	27 124 +2E*^
	0.15	6.0	12.0	13	0.6	10	15 Min.	280	27 154 +2E*^
	0.12	5.0	10.8	18.0	0.8	15	15 Min.	200	27 124 +2E*^
	0.15	5.0	10.8	18.0	0.8	15	15 Min.	200	27 154 +2E*^
	0.18	5.0	10.8	18.0	0.8	15	15 Min.	200	27 184 +2E*^
	0.22	5.0	10.8	18.0	0.8	15	15 Min.	200	27 224 +2E*^
	0.27	6.0	11.9	18.0	0.8	15	15 Min.	200	27 274 +2E*^
	0.33	6.0	11.9	18.0	0.8	15	15 Min.	200	27 334 +2E*^
	0.39	7.5	13.5	18.0	0.8	15	15 Min.	200	27 394 +2E*^
	0.47	7.5	13.5	18.0	0.8	15	15 Min.	200	27 474 +2E*^
	0.56	7.5	13.5	18.0	0.8	15	15 Min.	200	27 564 +2E*^
	0.68	8.5	14.5	18.0	0.8	15	15 Min.	200	27 684 +2E*^
	0.82	10.0	16.0	18.0	0.8	15	15 Min.	200	27 824 +2E*^
1	10.0	16.0	18.0	0.8	15	15 Min.	200	27 105 +2E*^	
0.39	6.0	15.0	26.5	0.8	22.5	15 Min.	125	27 394 +2E*^	
0.47	6.0	15.0	26.5	0.8	22.5	15 Min.	125	27 474 +2E*^	
0.56	6.0	15.0	26.5	0.8	22.5	15 Min.	125	27 564 +2E*^	
0.68	6.0	15.0	26.5	0.8	22.5	15 Min.	125	27 684 +2E*^	
0.82	7.0	16.0	26.5	0.8	22.5	15 Min.	125	27 824 +2E*^	
1	7.0	16.0	26.5	0.8	22.5	15 Min.	125	27 105 +2E*^	
1.2	8.5	17.0	26.5	0.8	22.5	15 Min.	125	27 125 +2E*^	
1.5	10.0	18.5	26.5	0.8	22.5	15 Min.	125	27 155 +2E*^	
1.8	10.0	18.5	26.5	0.8	22.5	15 Min.	125	27 185 +2E*^	

Rated Voltage	Rated Capacitance (μF)	Dimensions (mm)						dV/dt (V/μs)	Part Number
		W (±0.5)	H (±0.5)	L (±0.5)	d (±0.05)	S (±0.75)	I		
400Vdc/200Vac	0.015	4.0	9.0	13.0	0.6	10	15 Min.	420	27 333 +2G*^
	0.018	4.0	9.0	13.0	0.6	10	15 Min.	420	27 183 +2G*^
	0.022	4.0	9.0	13.0	0.6	10	15 Min.	420	27 223 +2G*^
	0.027	4.0	9.0	13.0	0.6	10	15 Min.	420	27 273 +2G*^
	0.033	5.0	11.0	13.0	0.6	10	15 Min.	420	27 333 +2G*^
	0.039	5.0	11.0	13.0	0.6	10	15 Min.	420	27 393 +2G*^
	0.047	5.0	11.0	13.0	0.6	10	15 Min.	420	27 473 +2G*^
	0.056	6.0	12.0	13.0	0.6	10	15 Min.	420	27 563 +2G*^
	0.068	6.0	12.0	13.0	0.6	10	15 Min.	420	27 683 +2G*^
	0.068	5.0	10.8	18.0	0.8	15	15 Min.	300	27 683 +2G*^

Metallized Polypropylene Film Capacitors

Box Type • Series Code 27



	0.082	5.0	10.8	18.0	0.8	15	15 Min.	300	27 823 +2G [^] A
	0.1	5.0	10.8	18.0	0.8	15	15 Min.	300	27 104 +2G [^] A
	0.12	6.0	11.9	18.0	0.8	15	15 Min.	300	27 124 +2G [^] A
	0.15	6.0	11.9	18.0	0.8	15	15 Min.	300	27 154 +2G [^] A
	0.18	7.5	13.5	18.0	0.8	15	15 Min.	300	27 184 +2G [^] A
	0.22	7.5	13.5	18.0	0.8	15	15 Min.	300	27 224 +2G [^] A
	0.27	8.5	14.5	18.0	0.8	15	15 Min.	300	27 334 +2G [^] A
	0.33	10.0	16.0	18.0	0.8	15	15 Min.	300	27 334 +2G [^] A
	0.18	6.0	15.0	26.5	0.8	22.5	15 Min.	180	27 184 +2G [^] A
	0.22	6.0	15.0	26.5	0.8	22.5	15 Min.	180	27 224 +2G [^] A
	0.27	6.0	15.0	26.5	0.8	22.5	15 Min.	180	27 274 +2G [^] A
	0.33	6.0	15.0	26.5	0.8	22.5	15 Min.	180	27 334 +2G [^] A
	0.39	7.0	16.0	26.5	0.8	22.5	15 Min.	180	27 394 +2G [^] A
	0.47	7.0	16.0	26.5	0.8	22.5	15 Min.	180	27 474 +2G [^] A
	0.56	7.0	16.0	26.5	0.8	22.5	15 Min.	180	27 564 +2G [^] A
	0.68	10.0	18.5	26.5	0.8	22.5	15 Min.	180	27 684 +2G [^] A
450Vdc	0.1	5.0	11.0	13.0	0.6	10	15 Min.	150	27 104 K 2I 1 A
	0.47	8.5	14.5	18.0	0.8	15	15 Min.	-	27 474 K 2I 1 B

Rated Voltage	Rated Capacitance (μF)	Dimensions (mm)					dV/dt (V/μs)	Part Number	
		W (±0.5)	H (±0.5)	L (±0.5)	d (±0.05)	S (±0.75)			
630Vdc/250Vac	0.001	4.0	9.0	13.0	0.6	10	15 Min.	550	27 102 +2J [^] A
	0.0012	4.0	9.0	13.0	0.6	10	15 Min.	550	27 122 +2J [^] A
	0.0015	4.0	9.0	13.0	0.6	10	15 Min.	550	27 152 +2J [^] A
	0.0018	4.0	9.0	13.0	0.6	10	15 Min.	550	27 182 +2J [^] A
	0.0022	4.0	9.0	13.0	0.6	10	15 Min.	550	27 222 +2J [^] A
	0.0027	4.0	9.0	13.0	0.6	10	15 Min.	550	27 272 +2J [^] A
	0.0033	4.0	9.0	13.0	0.6	10	15 Min.	550	27 332 +2J [^] A
	0.0039	4.0	9.0	13.0	0.6	10	15 Min.	550	27 392 +2J [^] A
	0.0047	4.0	9.0	13.0	0.6	10	15 Min.	550	27 472 +2J [^] A
	0.0056	4.0	9.0	13.0	0.6	10	15 Min.	550	27 562 +2J [^] A
	0.0068	4.0	9.0	13.0	0.6	10	15 Min.	550	27 682 +2J [^] A
	0.0082	4.0	9.0	13.0	0.6	10	15 Min.	550	27 822 +2J [^] A
	0.01	4.0	9.0	13.0	0.6	10	15 Min.	550	27 102 +2J [^] A
	0.012	4.0	9.0	13.0	0.6	10	15 Min.	550	27 123 +2J [^] A
	0.15	5.0	11.0	13.0	0.6	10	15 Min.	550	27 153 +2J [^] A
	0.18	5.0	11.0	13.0	0.6	10	15 Min.	550	27 183 +2J [^] A
	0.022	6.0	12.0	13.0	0.6	10	15 Min.	550	27 223 +2J [^] A
	0.027	6.0	12.0	13.0	0.6	10	15 Min.	550	27 273 +2J [^] A
	0.027	5.0	10.8	18.0	0.8	15	15 Min.	400	27 273 +2J [^] A
	0.033	5.0	10.8	18.0	0.8	15	15 Min.	400	27 333 +2J [^] A
0.047	5.0	10.8	18.0	0.8	15	15 Min.	400	27 473 +2J [^] A	
0.056	5.0	10.8	18.0	0.8	15	15 Min.	400	27 563 +2J [^] A	
0.068	6.0	11.9	18.0	0.8	15	15 Min.	400	27 683 +2J [^] A	
0.082	6.0	11.9	18.0	0.8	15	15 Min.	400	27 823 +2J [^] A	
0.1	7.5	13.5	18.0	0.8	15	15 Min.	400	27 104 +2J [^] A	

Metallized Polypropylene Film Capacitors

Box Type • Series Code 27

	0.1	6.0	12.0	18.0	0.8	15	15 Min.	400	27 104 K 2J 1 A
	0.12	7.5	13.5	18.0	0.8	15	15 Min.	400	27 124 +2J [^]
	0.15	8.5	14.5	18.0	0.8	15	15 Min.	400	27 154 +2J [^]
	0.18	10.0	16.0	18.0	0.8	15	15 Min.	400	27 184 +2J [^]
	0.22	10.0	16.0	18.0	0.8	15	15 Min.	400	27 224 +2J [^]
	0.082	6.0	15.0	26.5	0.8	22.5	15 Min.	250	27 823 +2J [^]
	0.1	6.0	15.0	26.5	0.8	22.5	15 Min.	250	27 104 +2J [^]
	0.12	6.0	15.0	26.5	0.8	22.5	15 Min.	250	27 124 +2J [^]
	0.15	6.0	15.0	26.5	0.8	22.5	15 Min.	250	27 154 K 2J 1 A
	0.18	7.0	16.0	26.5	0.8	22.5	15 Min.	250	27 184 +2J [^]
	0.22	7.0	16.0	26.5	0.8	22.5	15 Min.	250	27 224 +2J [^]
	0.27	8.5	17.0	26.5	0.8	22.5	15 Min.	250	27 274 +2J [^]
	0.33	10.0	18.5	26.5	0.8	22.5	15 Min.	250	27 334 +2J [^]
	0.33	10.0	19	26.5	0.8	22.5	15 Min.	250	27 334 K 2J 1 A
	0.39	10.0	18.5	26.5	0.8	22.5	15 Min.	250	27 394 +2J [^]
	0.47	7.0	16.5	26.0	0.8	22.5	15 Min.	250	27 474 K 2J 1 A
600Vdc	5.0	14.0	23.5	31.0	0.8	27.5	15 Min.	-	27 505 K 2V 1 A

*All dimension in mm, += capacitor tolerance, *=packing type,

** if any other enquiry please feel free contact to us rd@dekielectronics.com

Specific Data

Description	Value			
	Frequency	$C_R \leq 0.1 \mu\text{F}$	$0.1 \mu\text{F} < C_R \leq 1 \mu\text{F}$	$C_R > 1 \mu\text{F}$
Maximum tangent of loss angle (Tan δ)	1 kHz	0.0008	0.0008	0.001
	10 kHz	0.0015	0.0025	-
	100 kHz	0.0050	-	-
Voltage proof test between leads	1.6 times of the rated DC voltage for 2 second			
Insulation Resistance (R_{IS})	$C_R \leq 0.33 \mu\text{F}$	$C_R > 0.33 \mu\text{F}$		
(or) time constant $T = C_R \times R_{IS}$	$\geq 100000 \text{M}\Omega$	$\geq 30000 \text{ s}$		
at 25° C, relative humidity $\leq 70\%$				

Endurance Test

Loaded at 1.25 times of rated voltage at 85°C for 1000 hours.

After The Test

$\Delta C/C$: $\leq 10\%$ of initial value.

Increase of Tan δ : ≤ 0.005 at 1 kHz

Insulation Resistance : $\geq 50\%$ of the value mentioned in specific data.

Temperature Derating Graph

For temperature between 85°C and 100°C a derating factor of 1.25% per °C on the rated voltage V_R has to be applied.

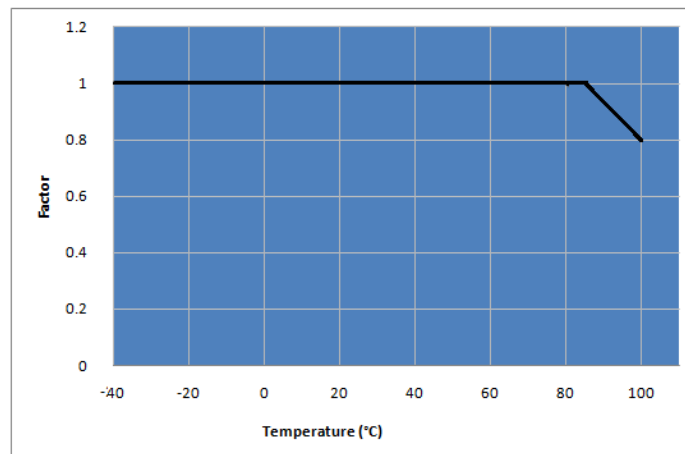

Power Dissipation and Maximum Component Temperature Rise

After applying the A.C voltage to the capacitor with certain frequency, we can measure the hot spot temperature of the capacitor. From that we can calculate ΔT .

ΔT = hot spot temperature – ambient temperature

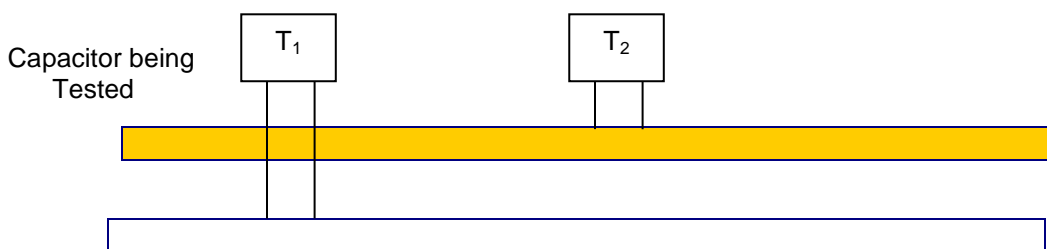

T_1 is the capacitor under test (Connected in the circuit)

T_2 is capacitor which has no connection

Distance between T_1 and T_2 should be about 50mm and 100mm from other components. To avoid radiation or convection, the capacitor should be tested in a wind-free box. The capacitor under test is separated by polystyrene.

$$\Delta T_{\max} = T_1 - T_2$$

at one frequency level the ΔT_{\max} reach 10°C. That is the frequency which we have to start frequency derating.

Storage Conditions

Avoid storing the capacitors in places where the environmental conditions differ from the following:

Storage time: ≤ 24 months from the date marked on the label glued to the package.

- Temperature: -40 to 80°C
- Humidity:
 - Average per year: $\leq 70\%$
 - For 30 full days randomly distributed throughout the year: $\leq 85\%$
 - Dew: absent

After a longer period of storage or use, the tolerance can increase; but, according to standard specification, it may never exceed twice the value measured at the time of delivery.

Disclaimer

All our capacitors are designed, manufactured and tested to specifications. We strictly adhere to standards in procurement of materials, in the laid down manufacturing processes and consistently apply stringent process controls and testing parameters. This ensures that our capacitors always perform to the offered specifications.

Appropriateness of use in a specific circuit and fitness to a particular application however needs to be verified and its reliability through expected lifetime is required to be validated by the customer. Deki's responsibility is limited to ensuring that the capacitor performs as claimed in the specification/ data sheets provided by Deki. Deki specifically disclaims any implied warranties of fitness for any particular purpose. Liability, in any case is limited to the price paid for the capacitors.