

COMPONENT SPECIFICATION

SERIES NAME AC & Pulse Double Side Metallized Polypropylene
Film Capacitors PP-MMPP (Box-Type)
SERIES CODE 66



GIVEN BY: DEKI ELECTRONICS LTD

DEKI ELECTRONICS LTD

B-20, SECTOR-58, NOIDA 201301

Tel: +91 120 2585457/58 • Fax: +91 120 2585289 • Email: rd@dekielectronics.com

Part Number Description

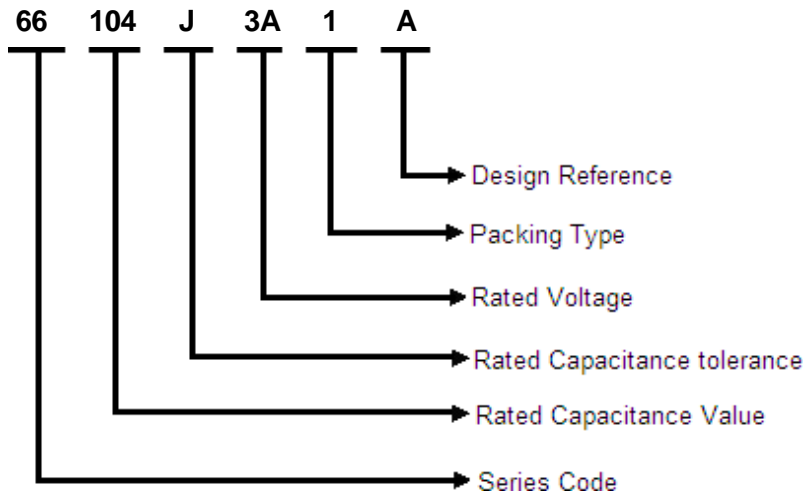

Rated Capacitance

Three-digit (104) indicate rated capacitance in Pico Farad (First two digits indicate value & third digit indicates number of zeroes to be suffixed to first two digits).

For example:

103 = 10 × 10 ³	= 10000 pF	= 10 nF	= 0.01 μF
104 = 10 × 10 ⁴	= 100000 pF	= 100 nF	= 0.1 μF
105 = 10 × 10 ⁵	= 1000000 pF	= 1000 nF	= 1 μF
106 = 10 × 10 ⁶	= 10000000 pF	= 10000 nF	= 10 μF

Capacitance Tolerance

In 3rd group of the part number-

F = ±1%, G = ±2%, H = ±2.5%, I = ±3.5%, J = ±5%, K = ±10%, L = ±15%, M = ±20%, N = ±40%

Rated Voltage

In 4th group of the part number, one numeric digit and one letter (Ex.-2A) indicate DC voltage rating while two numeric digits (Ex.05) indicate AC voltage rating.

Rated Voltage Codification

For DC Rated Voltage													
A		B		C		D		E		F		G	
1A	10	1B	12.5	1C	16	1D	20	1E	25	1F	30	1G	40
2A	100	2B	125	2C	160	2D	200	2E	250	2F	300	2G	400
3A	1000	3B	1250	3C	1600	3D	2000	3E	2500	3F	3000	3G	4000
H		I		J		K		L		M		N	
1H	50	1I	45	1J	63	1K	70	1L	80	1M	85	1N	90
2H	500	2I	450	2J	630	2K	700	2L	800	2M	850	2N	900
3H	5000	3I	4500	3J	6300	3K	7000	3L	8000	3M	8500	3N	9000
O		P		Q		R		S		U		V	
1O	110	1P	120	1Q	57.5	1R	15	1S	17	1U	130	1V	60
2O	1100	2P	1200	2Q	575	2R	150	2S	170	2U	1300	2V	600
3O	11000	3P	12000	3Q	5750	3R	1500	3S	1700	3U	13000	3V	6000
For AC Rated Voltage													
01	02	03	04	05	06	07	08	09	10	11	12	13	15
190 VAC	250 VAC	275 VAC	305 VAC	310 VAC	440 VAC	500 VAC	600 VAC	700 VAC	63 VAC	230 VAC	330 VAC	400 VAC	350 VAC

Packing Type

- 1: Bulk packing (original pitch)
- 2: Bulk packing (after forming & cutting)
- 3: Ammo packing (after forming & taping)
- 4: Bulk packing (after forming in original pitch without cut)
- 5: Bulk packing (after formed & without cut)
- 6: Ammo packing (Straight lead)
- 7: Bulk packing (Straight lead cut)
- 8: Reel packing (Straight lead)

Reference Data

Capacitance	0.001 μ F to 1.8 μ F
Capacitance Tolerance	\pm 5% and \pm 10%
Rated DC Voltage	630Vdc to 2000Vdc
Permissible rated AC voltage	400Vac to 700 Vac
Climatic testing class according to IEC 60068-1	40/105/56
Maximum application temperature	105°C
Rated temperature	85°C for rated DC voltage and 75°C for rated AC voltage
Reference standard	IEC 60384-16 & IEC 60384-17
Dielectric	Polypropylene
Electrodes	Double side metallized
Construction	Series
Encapsulation	Incased in flame retardant box filled with resin
Leads	Tinned wire
Marking on capacitor body	Type of capacitor, rated capacitance, rated tolerance and rated voltage will be available on each and every capacitor. Example- PP-MMPP D105J3D
Compatibility to RoHS	

Dimensions Description

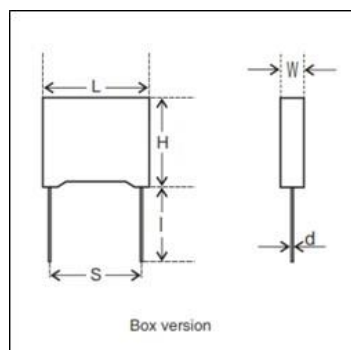

AC & Pulse Double Side Metallized Polypropylene Film Capacitors
PP-MMPP • Box Type • Series Code 66



Rated Voltage	Rated Capacitance (μF)	Dimension(mm)						Part Number
400Vdc/250Vac	0.047	13.0	13.0	7.5	10±0.75	0.6	15 Min.	66 473 J 2G 1 A
630Vdc/400Vac	0.01	13	11	5	10±0.75	0.6	15 Min.	66 103 J 2J 1 D
	0.012	13	11	5	10±0.75	0.6	15 Min.	66 123 J 2J 1 D
	0.012	18	11	5	15±0.75	0.8	15 Min.	66 123 J 2J 1 A
	0.015	13	12	6	10±0.75	0.6	15 Min.	66 153 J 2J 1 D
	0.015	18	11	5	15±0.75	0.8	15 Min.	66 153 J 2J 1 A
	0.018	13	12	6	10±0.75	0.6	15 Min.	66 183 J 2J 1 D
	0.018	18	11	5	15±0.75	0.8	15 Min.	66 183 J 2J 1 A
	0.022	18	11	5	15±0.75	0.8	15 Min.	66 223 J 2J 1 A
	0.022	18	12	6	15±0.75	0.8	15 Min.	66 223 J 2J 1 D
	0.027	18	11	5	15±0.75	0.8	15 Min.	66 273 J 2J 1 A
	0.033	18	12	6	15±0.75	0.8	15 Min.	66 333 J 2J 1 A
	0.033	13	13	7	10±0.75	0.6	15 Min.	66 333 J 2J 1 D
	0.039	13	16	7	10±0.75	0.8	15 Min.	66 393 J 2J 1 D
	0.039	18	12	6	15±0.75	0.8	15 Min.	66 393 J 2J 1 A
	0.047	18	13.5	7.5	15±0.75	0.8	15 Min.	66 473 J 2J 1 A
	0.047	26.5	15	6	22.5±1.0	0.8	15 Min.	66 473 J 2J 1 B
	0.056	18	13.5	7.5	15±0.75	0.8	15 Min.	66 563 J 2J 1 A
	0.056	26.5	15	6	22.5±1.0	0.8	15 Min.	66 563 J 2J 1 B
	0.068	18	14.5	8.5	15±0.75	0.8	15 Min.	66 683 J 2J 1 A
	0.068	26.5	15	6	22.5±1.0	0.8	15 Min.	66 683 J 2J 1 B
	0.082	18	14.5	8.5	15±0.75	0.8	15 Min.	66 823 J 2J 1 A
	0.082	26.5	15	6	22.5±1.0	0.8	15 Min.	66 823 J 2J 1 B
	0.1	18	16.5	10	15±0.75	0.8	15 Min.	66 104 J 2J 1 A
	0.1	26.5	15	6	22.5±1.0	0.8	15 Min.	66 104 J 2J 1 B
	0.1	18	14.5	8.5	15±0.75	0.8	15 Min.	66 104 K 2J 1 C
	0.12	18	19	11	15±0.75	0.8	15 Min.	66 124 J 2J 1 A
	0.12	26.5	16	7	22.5±1.0	0.8	15 Min.	66 124 J 2J 1 B
	0.15	26.5	15	8.5	22.5±1.0	0.8	15 Min.	66 154 J 2J 1 B
	0.15	32	19	7	27.5±1.0	0.8	15 Min.	66 154 J 2J 1 C
	0.18	26.5	15	8.5	22.5±1.0	0.8	15 Min.	66 184 J 2J 1 B
	0.18	32	19	7	27.5±1.0	0.8	15 Min.	66 184 J 2J 1 C
	0.22	26.5	18.5	10	22.5±1.0	0.8	15 Min.	66 224 J 2J 1 B
	0.22	32	19	7	27.5±1.0	0.8	15 Min.	66 224 J 2J 1 C
0.27	26.5	20	11	22.5±1.0	0.8	15 Min.	66 274 J 2J 1 B	
0.27	32	19	7	27.5±1.0	0.8	15 Min.	66 274 J 2J 1 C	
0.33	26.5	20	11	22.5±1.0	0.8	15 Min.	66 334 J 2J 1 B	
0.33	32	20	11	27.5±1.0	0.8	15 Min.	66 334 J 2J 1 C	
0.39	26.5	22	13	22.5±1.0	0.8	15 Min.	66 394 J 2J 1 B	
0.39	32	20	11	27.5±1.0	0.8	15 Min.	66 394 J 2J 1 C	
0.47	32	22	13	27.5±1.0	0.8	15 Min.	66 474 J 2J 1 C	
0.47	31	26	18	27.5±1.0	0.8	17 Min.	66 474 K 2J 1 H	
0.56	32	22	13	27.5±1.0	0.8	15 Min.	66 564 J 2J 1 C	

AC & Pulse Double Side Metallized Polypropylene Film Capacitors
PP-MMPP • Box Type • Series Code 66



630Vdc/400Vac	0.68	32	25	13	27.5±1.0	0.8	15 Min.	66 684 J 2J 1 C
	0.82	32	28	14	27.5±1.0	0.8	15 Min.	66 824 J 2J 1 C
	1	32	33	18	27.5±1.0	0.8	15 Min.	66 105 J 2J 1 C
	1.2	32	33	18	27.5±1.0	0.8	15 Min.	66 125 J 2J 1 C
	1.5	32	37	22	27.5±1.0	0.8	15 Min.	66 155 J 2J 1 C
	1.8	32	37	22	27.5±1.0	0.8	15 Min.	66 185 J 2J 1 C
700Vdc/400Vac	0.1	18	19	11	15.0±1.0	0.8	15 Min.	66 104 K 2K 1 A
1000Vdc/600Vac	0.0039	13	11	5	10±0.75	0.6	15 Min.	66 392 J 3A 1 D
	0.0047	13	11	5	10±0.75	0.6	15 Min.	66 472 J 3A 1 D
	0.0056	13	12	6	10±0.75	0.6	15 Min.	66 562 J 3A 1 D
	0.0068	13	12	6	10±0.75	0.6	15 Min.	66 682 J 3A 1 D
	0.0082	18	11	5	15±0.75	0.8	15 Min.	66 822 J 3A 1 A
	0.01	18	11	5	15±0.75	0.8	15 Min.	66 103 J 3A 1 A
	0.01	18	11	5	15±0.75	0.8	15 Min.	66 103 K 3A 1 A
	0.012	18	11	5	15±0.75	0.8	15 Min.	66 123 J 3A 1 A
	0.015	18	11	5	15±0.75	0.8	15 Min.	66 153 J 3A 1 A
	0.018	18	11	5	15±0.75	0.8	15 Min.	66 183 J 3A 1 A
	0.018	18	11	5	15±0.75	0.8	15 Min.	66 183 K 3A 1 A
	0.022	18	13	7	15±0.75	0.8	15 Min.	66 223 J 3A 1 A
	0.027	18	13.5	7.5	15±0.75	0.8	15 Min.	66 273 J 3A 1 A
	0.027	26.5	15	6	22.5±1.0	0.8	15 Min.	66 273 J 3A 1 B
	0.033	18	13.5	7.5	15±0.75	0.8	15 Min.	66 333 J 3A 1 A
	0.033	26.5	15	6	22.5±1.0	0.8	15 Min.	66 333 J 3A 1 B
	0.039	18	14.5	8.5	15±0.75	0.8	15 Min.	66 393 J 3A 1 A
	0.039	26.5	15	6	22.5±1.0	0.8	15 Min.	66 393 J 3A 1 B
	0.047	18	14.5	8.5	15±0.75	0.8	15 Min.	66 473 J 3A 1 A
	0.047	26.5	16	7	22.5±1.0	0.8	15 Min.	66 473 J 3A 1 B
	0.056	26.5	16	7	22.5±1.0	0.8	15 Min.	66 563 J 3A 1 B
	0.056	18	16	10	15±0.75	0.8	15 Min.	66 563 J 3A 1 A
	0.056	18	16	10	15±0.75	0.8	15 Min.	66 563 K 3A 1 A
	0.068	26.5	15	8.5	22.5±1.0	0.8	15 Min.	66 683 J 3A 1 B
	0.082	18.0	18.5	11	15±0.75	0.8	15 Min.	66 823 J 3A 1 A
	0.082	26.5	18.5	10	22.5±1.0	0.8	15 Min.	66 823 J 3A 1 B
	0.1	26.5	18.5	10	22.5±1.0	0.8	15 Min.	66 104 J 3A 1 B
	0.1	32	15	9	27.5±1.0	0.8	15 Min.	66 104 J 3A 1 C
	0.12	26.5	20	11	22.5±1.0	0.8	15 Min.	66 124 J 3A 1 B
	0.12	32	15	9	27.5±1.0	0.8	15 Min.	66 124 J 3A 1 C
	0.15	26.5	22	13	22.5±1.0	0.8	15 Min.	66 154 J 3A 1 B
	0.15	32	20	11	27.5±1.0	0.8	15 Min.	66 154 J 3A 1 C
	0.18	32	22	13	27.5±1.0	0.8	15 Min.	66 184 J 3A 1 C
	0.22	32	22	13	27.5±1.0	0.8	15 Min.	66 224 J 3A 1 C
	0.27	32	25	13	27.5±1.0	0.8	15 Min.	66 274 J 3A 1 C
	0.33	32	28	14	27.5±1.0	0.8	15 Min.	66 334 J 3A 1 C
0.39	32	33	18	27.5±1.0	0.8	15 Min.	66 394 J 3A 1 C	
0.47	32	33	18	27.5±1.0	0.8	15 Min.	66 474 J 3A 1 C	
0.56	32	37	22	27.5±1.0	0.8	15 Min.	66 564 J 3A 1 C	
0.68	32	37	22	27.5±1.0	0.8	15 Min.	66 684 J 3A 1 C	

AC & Pulse Double Side Metallized Polypropylene Film Capacitors
PP-MMPP • Box Type • Series Code 66



1600Vdc/650Vac	0.0068	18	11	5	15±0.75	0.8	15 Min.	66 682 J 3C 1 A
	0.0082	18	11	5	15±0.75	0.8	15 Min.	66 822 J 3C 1 A
	0.01	18	11	5	15±0.75	0.8	15 Min.	66 103 J 3C 1 A
	0.012	18	12	6	15±0.75	0.8	15 Min.	66 123 J 3C 1 A
	0.015	18	12	6	15±0.75	0.8	15 Min.	66 153 J 3C 1 A
	0.015	26.5	15	6	22.5±1.0	0.8	15 Min.	66 153 J 3C 1 B
	0.018	18	13.5	7.5	15±0.75	0.8	15 Min.	66 183 J 3C 1 A
	0.018	26.5	15	6	22.5±1.0	0.8	15 Min.	66 183 J 3C 1 B
	0.022	18	14	8	15±0.75	0.8	15 Min.	66 223 J 3C 1 A
	0.022	26.5	15	6	22.5±1.0	0.8	15 Min.	66 223 J 3C 1 B
	0.027	18	14.5	8.5	15±0.75	0.8	15 Min.	66 273 J 3C 1 A
	0.027	26.5	15	6	22.5±1.0	0.8	15 Min.	66 273 J 3C 1 B
	0.033	18	14.5	8.5	15±0.75	0.8	15 Min.	66 333 J 3C 1 A
	0.033	26.5	15	6	22.5±1.0	0.8	15 Min.	66 333 J 3C 1 B
	0.039	26.5	16	7	22.5±1.0	0.8	15 Min.	66 393 J 3C 1 B
	0.039	32	15	9	27.5±1.0	0.8	15 Min.	66 393 J 3C 1 C
	0.047	26.5	16	7	22.5±1.0	0.8	15 Min.	66 473 J 3C 1 B
	0.047	32	15	9	27.5±1.0	0.8	15 Min.	66 473 J 3C 1 C
	0.056	26.5	15	8.5	22.5±1.0	0.8	15 Min.	66 563 J 3C 1 B
	0.056	32	15	9	27.5±1.0	0.8	15 Min.	66 563 J 3C 1 C
	0.068	26.5	18.5	10	22.5±1.0	0.8	15 Min.	66 683 J 3C 1 B
	0.068	32	15	9	27.5±1.0	0.8	15 Min.	66 683 J 3C 1 C
	0.082	26.5	18.5	10	22.5±1.0	0.8	15 Min.	66 823 J 3C 1 B
	0.082	32	20	11	27.5±1.0	0.8	15 Min.	66 823 J 3C 1 C
	0.1	26.5	20	11	22.5±1.0	0.8	15 Min.	66 104 J 3C 1 B
	0.1	32	20	11	27.5±1.0	0.8	15 Min.	66 104 J 3C 1 C
	0.12	32	22	13	27.5±1.0	0.8	15 Min.	66 124 J 3C 1 C
	0.15	32	25	13	27.5±1.0	0.8	15 Min.	66 154 J 3C 1 C
	0.18	32	28	14	27.5±1.0	0.8	15 Min.	66 184 J 3C 1 C
	0.22	26	25	15	22.5±1.0	0.8	15 Min.	66 224 J 3C 1 B
	0.22	26	29	14.5	22.5±1.0	0.8	15 Min.	66 224 J 3C 1 D
	0.22	31	26	16.5	27.5±1.0	0.8	15 Min.	66 224 J 3C 1 E
	0.22	32	33	18	27.5±1.0	0.8	15 Min.	66 224 J 3C 1 C
	0.27	32	33	18	27.5±1.0	0.8	15 Min.	66 274 J 3C 1 C
	0.33	32	33	18	27.5±1.0	0.8	15 Min.	66 334 J 3C 1 C
	0.39	32	37	22	27.5±1.0	0.8	15 Min.	66 394 J 3C 1 C
0.47	32	37	22	27.5±1.0	0.8	15 Min.	66 474 J 3C 1 C	
2000Vdc/700Vac	0.001	18	11	5	15±0.75	0.8	15 Min.	66 102 J 3D 1 A
	0.0012	18	11	5	15±0.75	0.8	15 Min.	66 122 J 3D 1 A
	0.0012	26.5	15	6	22.5±1.0	0.8	15 Min.	66 122 J 3D 1 B
	0.0015	18	11	5	15±0.75	0.8	15 Min.	66 152 J 3D 1 A
	0.0015	26.5	15	6	22.5±1.0	0.8	15 Min.	66 152 J 3D 1 B
	0.0018	18	11	5	15±0.75	0.8	15 Min.	66 182 J 3D 1 A
	0.0018	26.5	15	6	22.5±1.0	0.8	15 Min.	66 182 J 3D 1 B
	0.0022	18	11	5	15±0.75	0.8	15 Min.	66 222 J 3D 1 A
	0.0022	26.5	15	6	22.5±1.0	0.8	15 Min.	66 222 J 3D 1 B
	0.0027	18	11	5	15±0.75	0.8	15 Min.	66 272 J 3D 1 A

AC & Pulse Double Side Metallized Polypropylene Film Capacitors

PP-MMPP • Box Type • Series Code 66



0.0027	26.5	15	6	22.5±1.0	0.8	15 Min.	66 272 J 3D 1 B
0.0033	18	11	5	15±0.75	0.8	15 Min.	66 332 J 3D 1 A
0.0033	26.5	15	6	22.5±1.0	0.8	15 Min.	66 332 J 3D 1 B
0.0039	18	11	5	15±0.75	0.8	15 Min.	66 392 J 3D 1 A
0.0039	26.5	15	6	22.5±1.0	0.8	15 Min.	66 392 J 3D 1 B
0.0047	18	11	5	15±0.75	0.8	15 Min.	66 472 J 3D 1 A
0.0047	26.5	15	6	22.5±1.0	0.8	15 Min.	66 472 J 3D 1 B
0.0056	18	12	6	15±0.75	0.8	15 Min.	66 562 J 3D 1 A
0.0056	26.5	15	6	22.5±1.0	0.8	15 Min.	66 562 J 3D 1 B
0.0068	18	12	6	15±0.75	0.8	15 Min.	66 682 J 3D 1 A
0.0068	26.5	15	6	22.5±1.0	0.8	15 Min.	66 682 J 3D 1 B
0.0082	18	12	6	15±0.75	0.8	15 Min.	66 822 J 3D 1 A
0.0082	26.5	15	6	22.5±1.0	0.8	15 Min.	66 822 J 3D 1 B
0.01	18	13.5	7.5	15±0.75	0.8	15 Min.	66 103 J 3D 1 A
0.01	26.5	15	6	22.5±1.0	0.8	15 Min.	66 103 J 3D 1 B
0.012	18	14.5	8.5	15±0.75	0.8	15 Min.	66 123 J 3D 1 A
0.012	26.5	15	6	22.5±1.0	0.8	15 Min.	66 123 J 3D 1 B
0.015	18	14.5	8.5	15±0.75	0.8	15 Min.	66 153 J 3D 1 A
0.015	26.5	15	6	22.5±1.0	0.8	15 Min.	66 153 J 3D 1 B
0.018	26.5	15	6	22.5±1.0	0.8	15 Min.	66 183 J 3D 1 B
0.022	26.5	16	7	22.5±1.0	0.8	15 Min.	66 223 J 3D 1 B
0.022	32	15	9	27.5±1.0	0.8	15 Min.	66 223 J 3D 1 C
0.027	26.5	15	6	22.5±1.0	0.8	15 Min.	66 273 J 3D 1 B
0.027	32	15	9	27.5±1.0	0.8	15 Min.	66 273 J 3D 1 C
0.033	26.5	17	8.5	22.5±1.0	0.8	15 Min.	66 333 J 3D 1 B
0.033	32	15	9	27.5±1.0	0.8	15 Min.	66 333 J 3D 1 C
0.039	26.5	18.5	10	22.5±1.0	0.8	15 Min.	66 393 J 3D 1 B
0.039	32	15	9	27.5±1.0	0.8	15 Min.	66 393 J 3D 1 C
0.047	26.5	18.5	10	22.5±1.0	0.8	15 Min.	66 473 J 3D 1 B
0.047	26.5	18.5	10	22.5±1.0	0.8	15 Min.	66 473 K 3D 1 B
0.047	32	20	11	27.5±1.0	0.8	15 Min.	66 473 J 3D 1 C
0.056	26.5	20	11	22.5±1.0	0.8	15 Min.	66 563 J 3D 1 B
0.056	32	22	13	27.5±1.0	0.8	15 Min.	66 563 J 3D 1 C
0.068	32	22	13	27.5±1.0	0.8	15 Min.	66 683 J 3D 1 C
0.082	32	25	13	22.5±1.0	0.8	15 Min.	66 823 J 3D 1 C
0.1	32	28	14	27.5±1.0	0.8	15 Min.	66 104 J 3D 1 C
0.12	32	33	18	27.5±1.0	0.8	15 Min.	66 124 J 3D 1 C

Specific Data

Description	Value	
Maximum tangent of loss angle (Tan δ)	0.001 at 1 kHz	
Voltage proof test between leads	1.6 times of the rated DC voltage for 5 second	
Insulation Resistance (R _{IS}) (or) time constant T= C _R × R _{IS} at 25° C, relative humidity ≤70%	C _R ≤0.33μF	C _R >0.33μF
	≥100000MΩ	≥30000 s

Endurance Test

Loaded at 1.25 times of rated dc voltage at 85°C or 1.25 times of the category voltage at 105°C for 2000 hours. Or loaded at 1.1 times of rated ac voltage at 75°C or 1.1 times of the category voltage at 105°C for 2000 hours. Category voltage is 80% of the rated voltage.

After The Test

- $\Delta C/C$: $\leq 10\%$ of initial value.
- Increase of $\tan \delta$: ≤ 0.005 at 1 kHz
- Insulation resistance : $\geq 50\%$ of the value mentioned in specific data.

Vrms Versus frequency Derating Graph

(For ambient temp T_A : $\leq 55^\circ\text{C}$ in Polyester and $\leq 85^\circ\text{C}$ in Polypropylene)

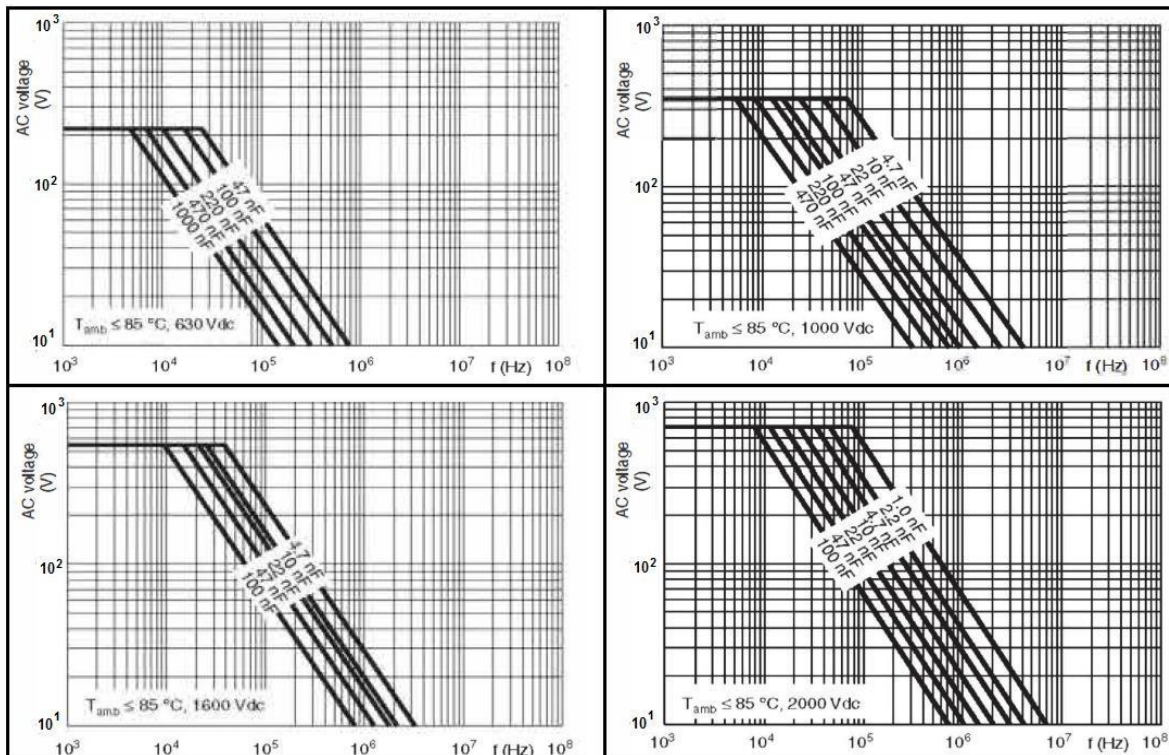

Temperature Derating Graph (For Rated DC Voltage)

For temperature between 85°C and 105°C a de-rating factor of 1.25% per °C on the rated voltage V_R has to be applied.

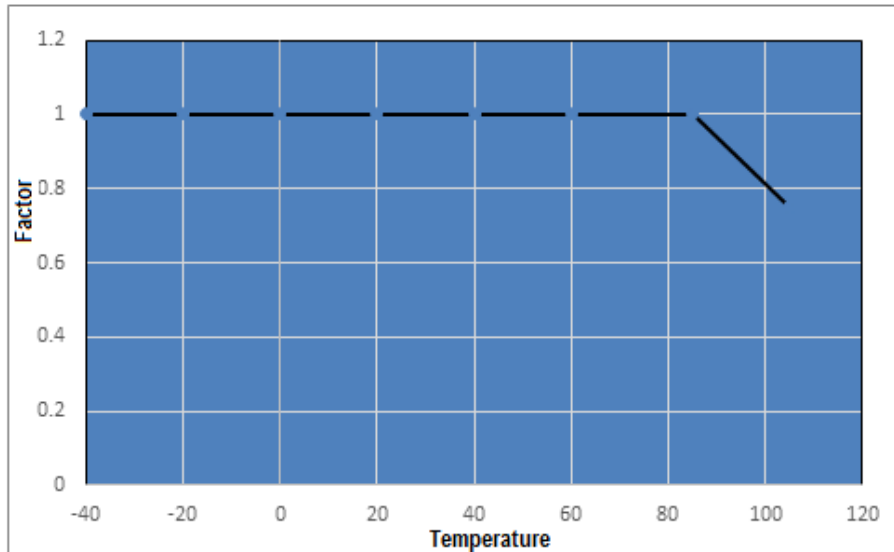

*For rated AC voltage temperature, derating starts from 75°C.

Power Dissipation and Maximum Component Temperature Rise

After applying the A.C voltage to the capacitor with certain frequency, we can measure the hot spot temperature of the capacitor. From that we can calculate ΔT .

ΔT = hot spot temperature - ambient temperature

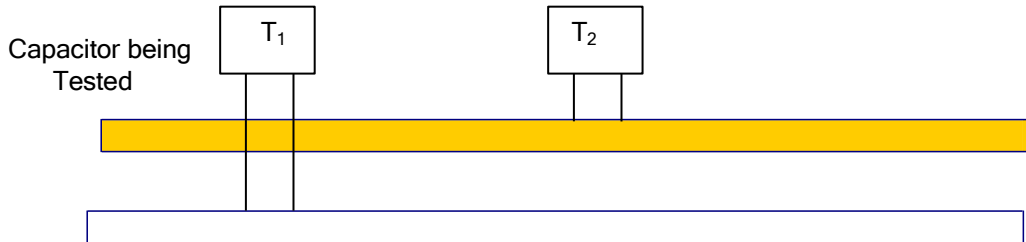

T_1 is the capacitor under test (Connected in the circuit)

T_2 is capacitor which has no connection

Distance between T_1 and T_2 should be about 50mm and 100mm from other components. To avoid radiation or convection, the capacitor should be tested in a wind-free box. The capacitor under test is separated by polystyrene.

$$\Delta T_{\max} = T_1 - T_2$$

at one frequency level the ΔT_{\max} reach 10°C . That is the frequency which we have to start frequency derating.

Storage Conditions

Avoid storing the capacitors in places where the environmental conditions differ from the following:

Storage time: ≤ 24 months from the date marked on the label glued to the package.

- Temperature: -40 to 80°C
- Humidity:
 - Average per year: $\leq 70\%$
 - For 30 full days randomly distributed throughout the year: $\leq 85\%$
 - Dew: absent

After a longer period of storage or use, the tolerance can increase; but, according to standard specification, it may never exceed twice the value measured at the time of delivery.

Disclaimer

All our capacitors are designed, manufactured and tested to specifications. We strictly adhere to standards in procurement of materials, in the laid down manufacturing processes and consistently apply stringent process controls and testing parameters. This ensures that our capacitors always perform to the offered specifications.

Appropriateness of use in a specific circuit and fitness to a particular application however needs to be verified and its reliability through expected lifetime is required to be validated by the customer. Deki's responsibility is limited ensuring that the capacitor performs as claimed in the specification/ data sheets provided by Deki.

Deki specifically disclaims any implied warranties of fitness for any particular purpose. Liability, in any case is limited to the price paid for the capacitor.