

COMPONENT SPECIFICATION

SERIES NAME Metallized Polypropylene Round Axial Film
Capacitor (MPP Round Axial)
SERIES CODE 40



GIVEN BY: DEKI ELECTRONICS LTD

DEKI ELECTRONICS LTD

B-20, SECTOR-58, NOIDA 201301

Tel: +91 120 2585457/58 • Fax: +91 120 2585289 • Email: rd@dekielectronics.com

Item Code Description

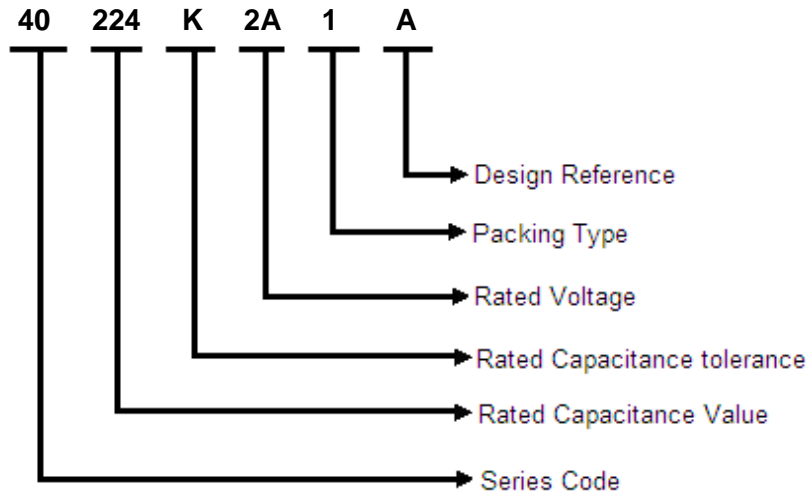

Rated Capacitance

Three-digit (224) indicate rated capacitance in Pico Farad (First two digits indicate value & third digit indicates number of zeroes to be suffixed to first two digits).

For example:

103 = 10 × 10 ³	= 10000 pF	= 10 nF	= 0.01 μF
104 = 10 × 10 ⁴	= 100000 pF	= 100 nF	= 0.1 μF
105 = 10 × 10 ⁵	= 1000000 pF	= 1000 nF	= 1 μF
106 = 10 × 10 ⁶	= 10000000 pF	= 10000 nF	= 10 μF

Capacitance Tolerance

F = ±1%, G = ±2%, H = ±2.5%, I = ±3.5%, J = ±5%, K = ±10%, L = ±15%, M = ±20%, N=±40%

Rated Voltage

One digit and one letter (2A) or two digits (05) indicate rated voltage.

Rated Voltage Codification

For DC Rated Voltage													
A		B		C		D		E		F		G	
1A	10	1B	12.5	1C	16	1D	20	1E	25	1F	30	1G	40
2A	100	2B	125	2C	160	2D	200	2E	250	2F	300	2G	400
3A	1000	3B	1250	3C	1600	3D	2000	3E	2500	3F	3000	3G	4000
H		I		J		K		L		M		N	
1H	50	1I	45	1J	63	1K	70	1L	80	1M	85	1N	90
2H	500	2I	450	2J	630	2K	700	2L	800	2M	850	2N	900
3H	5000	3I	4500	3J	6300	3K	7000	3L	8000	3M	8500	3N	9000
O		P		Q		R		S		T		U	
1O	110	1P	120	1Q	57.5	1R	15	1S	17	1T	70	1U	130
2O	1100	2P	1200	2Q	575	2R	150	2S	170	2T	700	2U	1300
3O	11000	3P	12000	3Q	5750	3R	1500	3S	1700	3T	70000	3U	13000

For AC Rated Voltage													
01	02	03	04	05	06	07	08	09	10	11	12	13	14
190	250	275	305	310	440	500	600	700	63	230	330	400	450
VAC	VAC	VAC	VAC	VAC	VAC	VAC	VAC	VAC	VAC	VAC	VAC	VAC	VAC

Packing Type

- 1: Bulk packing (original pitch)
- 2: Bulk packing (after forming & cutting)
- 3: Ammo packing (after forming & taping)
- 4: Bulk packing (after forming in original pitch without cut)
- 5: Bulk packing (after formed & without cut)
- 6: Ammo packing (Straight lead)
- 7: Bulk packing (Straight lead cut)
- 8: Reel packing (Straight lead)

Reference Data

Capacitance	0.0047μF to 10μF
Capacitance tolerance	±5% , ±10%
Rated DC Voltage	250Vdc to 1000Vdc
Climatic testing class according to IEC 60068-1	40/100/21
Maximum application temperature	100°C
Rated temperature	85°C
Reference standards	IEC 60384-16
Dielectric	Polypropylene
Electrodes	Metallized
Construction	Mono
Encapsulation	Polyester tape wrapped
Leads	Tinned wire
Marking example on capacitor body	Type of capacitor, rated capacitance, rated tolerance and rated voltage will be available on each and every capacitor. Example- MPP D105K2J

Compatibility to RoHS 

Dimensions Description

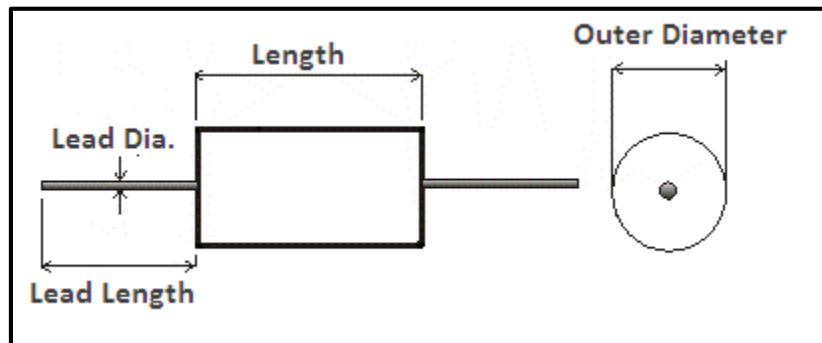

Metallized Polypropylene Round Axial Film Capacitor

MPP Round Axial • Series Code 40



Rated Voltage	Rated Capacitance (μF)	Length (Max)	Dimensions (mm)			Item Code
			Outer Diameter (Max)	Lead Dia. (±0.05)	Lead Length (Min.)	
400Vdc	1.0	35.0	13.5	0.8	30	40 105 J 2G 1 B
630Vdc	1.0	34.0	17.0	0.8	30	40 105 K 2J 1 I
400Vdc	2.2	34.0	23.0	0.8	30	40 225 K 2G 1 E
400Vdc	0.25	22.0	9.0	0.6	30	40 254 K 2G 1 A

** if any other enquiry please feel free contact to us rohit@dekielectronics.com , rd@dekielectronics.com

Specific Data

Description	Value			
Maximum tangent of loss angle (Tanδ)	Frequency	$C_R \leq 0.1\mu F$	$0.1\mu F < C_R \leq 1\mu F$	$C_R > 1\mu F$
	1 kHz	0.0008	0.0008	0.001
	10 kHz	0.0015	0.0025	-
	100 kHz	0.0050	-	-
Voltage proof test between leads	1.6 times of the rated DC voltage for 2 second			
Insulation Resistance (R_{IS}) (or) time constant $T = C_R \times R_{IS}$ at 25° C, relative humidity ≤70%	$C_R \leq 0.33\mu F$	$C_R > 0.33\mu F$		
		≥100000MΩ	≥30000 s	

Endurance Test

Loaded at 1.25 times of rated voltage at 85°C for 1000 hours.

After The Test

- $\Delta C/C$: ≤ 10% of initial value.
- Increase of Tanδ : ≤ 0.005
- Insulation Resistance : ≥ 50% of the value mentioned in specific data.

Temperature Derating Graph

For temperature between 85°C and 100°C a derating factor of 1.25% per °C on the rated voltage V_R has to be applied.

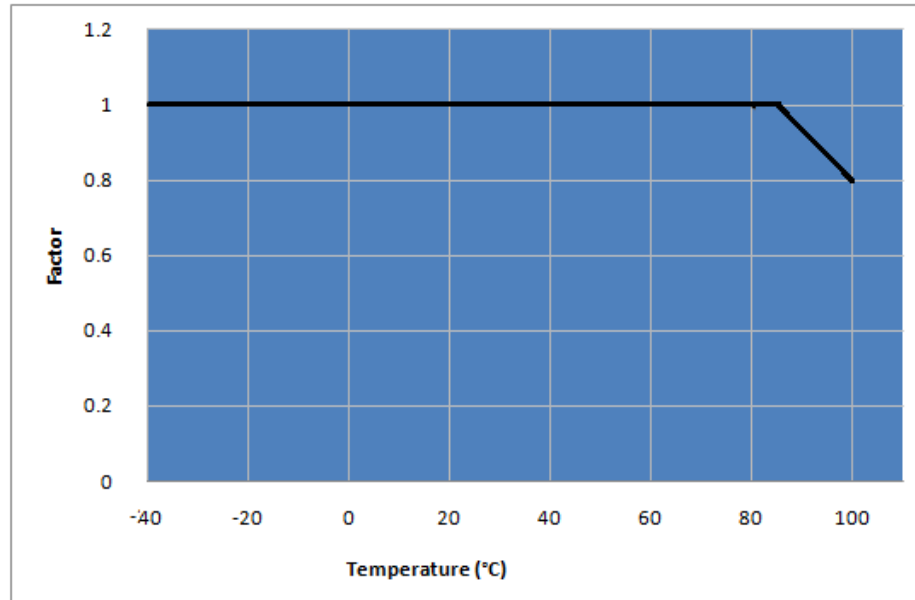

Storage Conditions

Avoid storing the capacitors in places where the environmental conditions differ from the following:

- Storage time: ≤ 24 months from the date marked on the label glued to the package.
- Temperature: -40 to 80°C
- Humidity:
 - Average per year: $\leq 70\%$
 - For 30 full days randomly distributed throughout the year: $\leq 85\%$
 - Dew: absent

After a longer period of storage or use, the tolerance can increase; but, according to standard specification, it may never exceed twice the value measured at the time of delivery.

Disclaimer

All our capacitors are designed, manufactured and tested to specifications. We strictly adhere to standards in procurement of materials, in the laid down manufacturing processes and consistently apply stringent process controls and testing parameters. This ensures that our capacitors always perform to the offered specifications.

Appropriateness of use in a specific circuit and fitness to a particular application however needs to be verified and its reliability through expected lifetime is required to be validated by the customer. Deki's responsibility is limited to ensuring that the capacitor performs as claimed in the specification/ data sheets provided by Deki. Deki specifically disclaims any implied warranties of fitness for any particular purpose. Liability, in any case is limited to the price paid for the capacitors.