

COMPONENT SPECIFICATION

SERIES NAME MOTOR RUN CAPACITOR-FASTON
TERMINALS

DEKI SERIES NO. 221



GIVEN BY: DEKI ELECTRONICS LTD •

DEKI ELECTRONICS LTD

B-20, SECTOR-58, NOIDA 201301

Tel: +91 120 2585457/58 • Fax: +91 120 2585289 • Email: rd@dekielectronics.com

Part Number Description

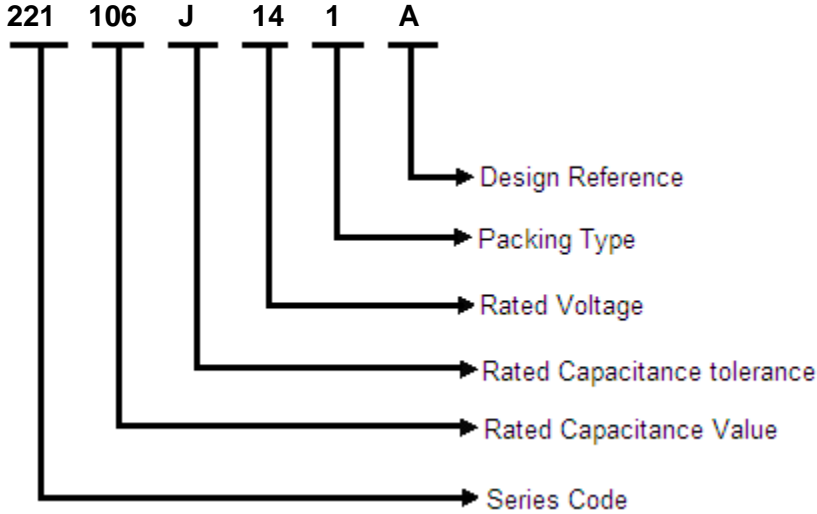

Rated Capacitance

Three-digit (105) indicate rated capacitance in Pico Farad (First two digits indicate value & third digit indicates number of zeroes to be suffixed to first two digits).

For example:

103	= 10 × 10 ³	= 10000 pF	= 10 nF	= 0.01 μF
104	= 10 × 10 ⁴	= 100000 pF	= 100 nF	= 0.1 μF
105	= 10 × 10 ⁵	= 1000000 pF	= 1000 nF	= 1 μF
106	= 10 × 10 ⁶	= 10000000 pF	= 10000 nF	= 10 μF

Capacitance Tolerance

In 3rd group of the part number-

F = ±1%, G = ±2%, H = ±2.5%, I = ±3.5%, J = ±5%, K = ±10%, L = ±15%, M = ±20%, N = ±40%

Rated Voltage

In 4th group of the part number, two numeric digits indicate AC voltage rating.

Rated Voltage Codification

For AC Rated Voltage															
01	02	03	04	05	06	07	08	09	10	11	12	13	14	15	16
190	250	275	305	310	440	500	600	700	63	230	330	400	450	350	300
VAC	VAC	VAC	VAC	VAC	VAC	VAC	VAC	VAC	VAC	VAC	VAC	VAC	VAC	VAC	VAC

Packing Type

- 1- Bulk Packing

General Data

Features

- Good Self-healing properties
- Minimal internal power losses
- High insulation resistance
- IS 2993 compliance
- Wide climatic category
- RoHS Compliance

Construction

- Dielectric: polypropylene film
- Plastic case
- Polyurethane Resin
- Dry type



Terminals

- Tin plated Faston terminals

Applications

- To be used as motor run capacitor

Reference Data

Climatic testing class according to IEC 60068-1	40/85/21
Rated Capacitance range	1 to 100 MFD
Capacitance Tol.	±5%(J)
Rated temperature	-40°C ~ +85°C
Rated Voltage (UN)	450 VAC
Reference standards	IS : 2993-1998
Dielectric	Metallized Polypropylene
Safety Approval Mark	P0
Class of Operation	Class-B
Expected life(IS:2993)	10000Hrs (failure rate not exceeding 3 %)
Frequency	50 Hz
Altitude	≤2000m
Encapsulation	Encased in Plastic Round Can filled with resin
Leads	Tin plated Faston terminals
Marking	 <p> Deki IS : 2993 MPP-SH  XXX µF±5% 450 VAC 50Hz 40/85/21 B P0 DEKI ELECTRONICS LTD. RoHS MM/YY LOT NO. </p>

Dimension Description

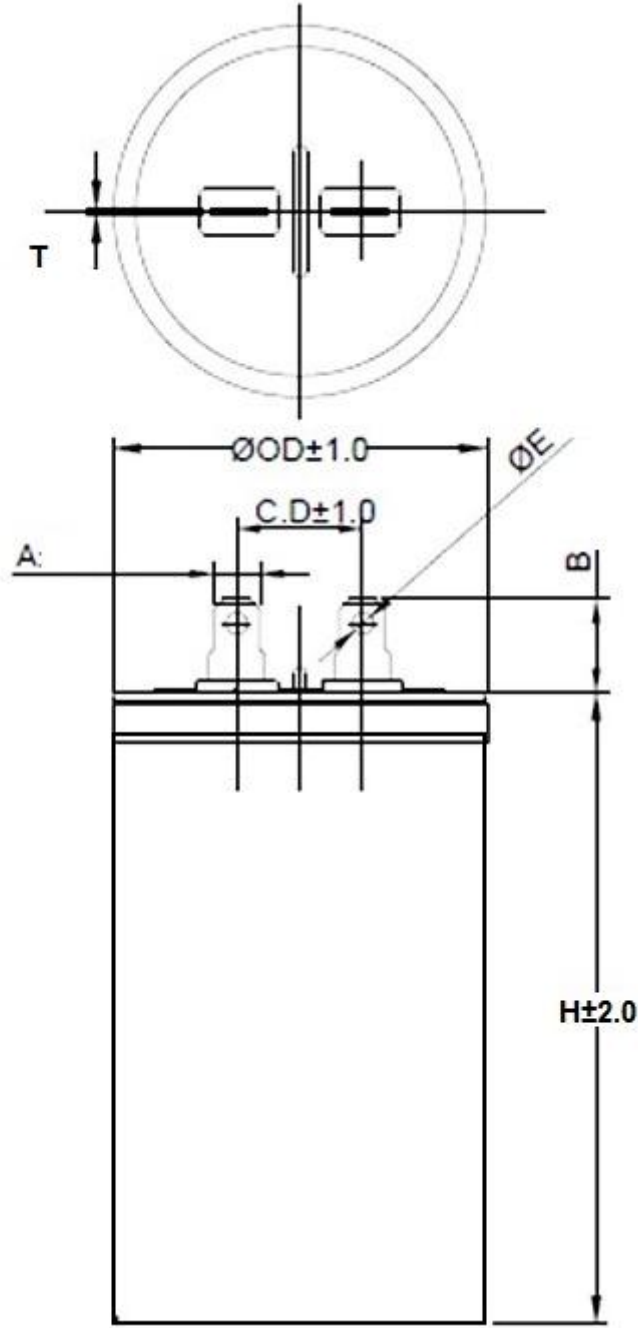

All dimensions are in mm

Part Number	Cap.	Tolerance	OD	Height (H)	A	B	C.D	ΦE	T
	μF		±1.0	±2.0	±0.2	±1.0	±1.0	±0.2	±0.05
221 205 J 14 1 *	2.0	±5%	30.0	54.0	6.3	10.0	17.0	1.8	0.8
221 255 J 14 1 *	2.5	±5%	30.0	54.0	6.3	10.0	17.0	1.8	0.8
221 305 J 14 1 *	3.0	±5%	30.0	54.0	6.3	10.0	17.0	1.8	0.8
221 405 J 14 1 *	4.0	±5%	30.0	54.0	6.3	10.0	17.0	1.8	0.8
221 505 J 14 1 *	5.0	±5%	30.0	54.0	6.3	10.0	17.0	1.8	0.8
221 605 J 14 1 *	6.0	±5%	30.0	54.0	6.3	10.0	17.0	1.8	0.8
221 805 J 14 1 *	8.0	±5%	30.0	54.0	6.3	10.0	17.0	1.8	0.8
221 106 J 14 1 *	10.0	±5%	35.0	54.0	6.3	10.0	17.0	1.8	0.8
221 156 J 14 1 *	15.0	±5%	35.0	71.0	6.3	10.0	17.0	1.8	0.8
221 206 J 14 1 *	20.0	±5%	40.0	71.0	6.3	10.0	17.0	1.8	0.8
221 256 J 14 1 *	25.0	±5%	40.0	71.0	6.3	10.0	17.0	1.8	0.8
221 306 J 14 1 *	30.0	±5%	45.0	71.0	6.3	10.0	17.0	1.8	0.8
221 366 J 14 1 *	36.0	±5%	40.0	95.0	6.3	10.0	17.0	1.8	0.8
221 406 J 14 1 *	40.0	±5%	45.0	95.0	6.3	10.0	17.0	1.8	0.8
221 456 J 14 1 *	45.0	±5%	45.0	95.0	6.3	10.0	17.0	1.8	0.8
221 506 J 14 1 *	50.0	±5%	50.0	95.0	6.3	10.0	17.0	1.8	0.8
221 606 J 14 1 *	60.0	±5%	50.0	95.0	6.3	10.0	17.0	1.8	0.8
221 726 J 14 1 *	72.0	±5%	50.0	120.0	6.3	10.0	17.0	1.8	0.8
221 806 J 14 1 *	80.0	±5%	50.0	120.0	6.3	10.0	17.0	1.8	0.8

*Internal design code

Specific Data

Description	Value
Maximum tangent of loss angle (Tan δ)	≤ 0.002 at 100Hz
Voltage proof test between leads	2 times of Rated Voltage at 2 Sec. (Routine test)
	2 times of Rated Voltage at 60 Sec. (Type test)
Voltage proof test between lead and case	2000Vac for 60 sec.(Type test)
Insulations resistance or time constant ($C_R \times R_{IS}$) between leads at 500 Vdc	$\geq 3000s$
Maximum Rate of Voltage rise (dv/dt max)	10V/ μs

Endurance Test

Test condition:

- Voltage: 1.25 x UN or 1.35 x UN
- Temperature: 85°C
- Duration: 2000Hrs or 1000Hrs

Test requirements:

- No visible damage
- Change in capacitance: $\leq 3\%$

Packing Box

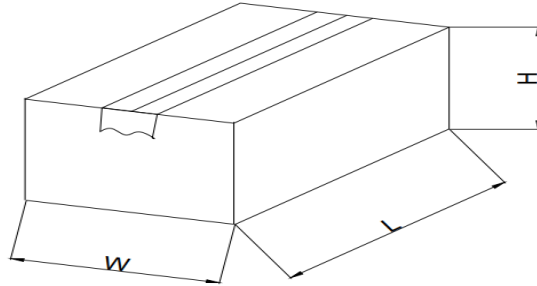

Capacitor Size	L	W	H	Quantity
30x54	335	167	80	50
35x54	335	167	80	50
35x71	335	167	100	50
40x95	250	250	115	25
45x95	250	250	115	25
50x95	280	280	115	25
50x120	280	280	150	25

Disclaimer

Perform to the offered specifications.

Appropriateness of use in a specific circuit and fitness to a particular application however needs to be verified and its reliability through expected lifetime is required to be validated by the customer. Deki's responsibility is limited to ensuring that the capacitor performs as claimed in the specification/ data sheets provided by Deki. Deki specifically disclaims any implied warranties of fitness for any particular purpose. Liability, in any case is limited to the price paid for the capacitors.