

COMPONENT SPECIFICATION

SERIES NAME Motor run Capacitors for submersible pumps

DEKI SERIES NO. 213



GIVEN BY: DEKI ELECTRONICS LTD • **APPROVED BY:** ROHIT

DEKI ELECTRONICS LTD

B-20, SECTOR-58, NOIDA 201301

Tel: +91 120 2585457/58 • Fax: +91 120 2585289 • Email: rd@dekielectronics.com

Part Number Description

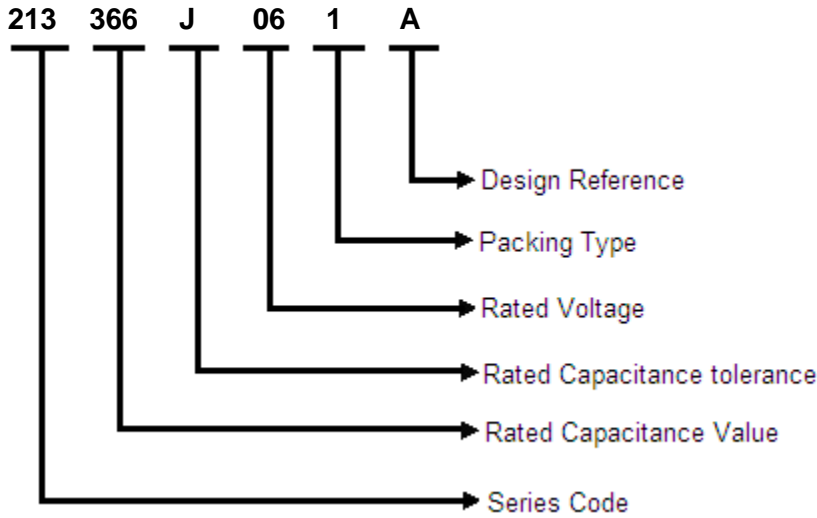

Rated Capacitance

Three-digit (105) indicate rated capacitance in Pico Farad (First two digits indicate value & third digit indicates number of zeroes to be suffixed to first two digits).

For example:

$$103 = 10 \times 10^3 = 10000 \text{ pF} = 10 \text{ nF} = 0.01 \mu\text{F}$$

$$104 = 10 \times 10^4 = 100000 \text{ pF} = 100 \text{ nF} = 0.1 \mu\text{F}$$

$$105 = 10 \times 10^5 = 1000000 \text{ pF} = 1000 \text{ nF} = 1 \mu\text{F}$$

$$106 = 10 \times 10^6 = 10000000 \text{ pF} = 10000 \text{ nF} = 10 \mu\text{F}$$

Capacitance Tolerance

In 3rd group of the part number-

F = ±1%, G = ±2%, H = ±2.5%, I = ±3.5%, J = ±5%, K = ±10%, L = ±15%, M = ±20%, N = ±40%

Rated Voltage

In 4th group of the part number, two numeric digits indicate AC voltage rating.

Rated Voltage Codification

For AC Rated Voltage															
01	02	03	04	05	06	07	08	09	10	11	12	13	14	15	16
190	250	275	305	310	440	500	600	700	63	230	330	400	450	350	300
VAC	VAC	VAC	VAC	VAC	VAC	VAC	VAC	VAC	VAC	VAC	VAC	VAC	VAC	VAC	VAC

Packing Type

- 1: Bulk packing (original pitch)
- 2: Bulk packing (after forming & cutting)
- 3: Ammo packing (after forming & taping)
- 4: Bulk packing (after forming in original pitch without cut)
- 5: Bulk packing (after formed & without cut)
- 6: Ammo packing (Straight lead)
- 7: Bulk packing (Straight lead cut)
- 8: Reel packing (Straight lead)

Motor run Capacitors for submersible pumps

Features

- Good Self-healing properties
- Minimal internal power losses
- High insulation resistance
- IS 2993 compliance
- Long life
- Wide climatic category

Construction

- Dielectric: polypropylene film
- Plastic case
- Polyurethane resin
- Dry type

Terminals

- Wire with sleeve

Applications

- To be used as motor run capacitor in Submersible pump application.

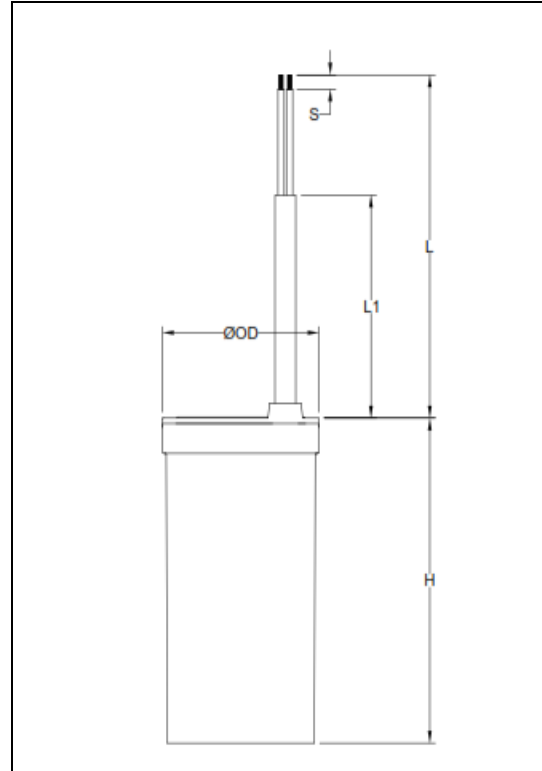

Range

- 20 to 100 μ F

Reference Data

Climatic testing class according to IEC 60068-1	40/85/21
Rated temperature	85°C
Reference standards	IS : 2993-1998
Electrodes	Metallized
Construction	Mono
Rated voltage at 50 Hz	450 VAC

Marking example

Deki
XXX MFD \pm 5% 450VAC LONG LIFE
50 Hz MPP-SH 40/85/21
MADE IN INDIA MM/YY
"For Submersible Pump Application"

Dimension Description

Part Number	Cap. (µF)	Tolerance	Diameter (OD±1.0)	Height (H±1.0)	Wire Length (L±5mm)	Sleeve Length (L1±10)	Striping (S±2.0)	Wire Spec.
213 246 J 14 1 B	24	±5%	40	96	205	125	10	16/0.2
213 306 J 14 1 B	30	±5%	40	96	205	125	10	24/0.2
213 366 J 06 1 A	36	±5%	45	96	205	125	10	24/0.2
213 366 J 14 1 A	36	±5%	45	96	205	125	10	24/0.2
213 366 J 14 1 B	36	±5%	45	96	205	125	10	24/0.2
213 366 J 14 1 D	36	±5%	45	96	205	125	10	24/0.2
213 366 J 14 1 E	36	±5%	45	120	205	125	10	24/0.2
213 406 J 14 1 A	40	±5%	45	96	205	125	10	24/0.2
213 406 J 14 1 B	40	±5%	45	96	205	125	10	24/0.2
213 456 J 14 1 A	45	±5%	45	96	205	125	10	24/0.2
213 456 J 14 1 D	45	±5%	40	96	205	125	10	24/0.2
213 506 J 06 1 A	50	±5%	45	96	205	125	10	24/0.2
213 506 J 14 1 A	50	±5%	45	96	205	125	10	24/0.2
213 506 J 14 1 B	50	±5%	45	96	205	125	10	24/0.2
213 506 J 14 1 D	50	±5%	45	120	205	125	10	24/0.2
213 506 J 14 1 F	50	±5%	45	120	205	125	10	24/0.2
213 606 J 14 1 A	60	±5%	45	96	205	125	10	32/0.2
213 606 J 14 1 B	60	±5%	45	96	205	125	10	32/0.2
213 606 J 14 1 D	60	±5%	50	96	205	125	10	32/0.2
213 726 J 06 1 A	72	±5%	45	96	205	125	10	32/0.2
213 726 J 14 1 A	72	±5%	45	96	205	125	10	32/0.2
213 726 J 14 1 B	72	±5%	50	120	205	125	10	32/0.2
213 726 J 14 1 D	72	±5%	45	120	205	125	10	32/0.2
213 726 J 14 1 F	72	±5%	50	96	205	125	10	32/0.2
213 107 J 14 1 B	100	±5%	50	120	205	125	10	32/0.2

*All dimension in mm

Specific Data

Description	Value
Maximum tangent of loss angle (Tanδ)	≤0.01 at 1 kHz
Voltage proof test between leads	2 times of Rated Voltage at 2 Sec.
Insulations resistance between leads at 500 Vdc	>2500s

Storage Conditions

Avoid storing the capacitors in places where the environmental conditions differ from the following:

- Storage time: ≤ 24 months from the date marked on the label glued to the package.
- Temperature: -40 to 85°C
- Humidity:
 - Average per year: $\leq 70\%$
 - For 30 full days randomly distributed throughout the year: $\leq 85\%$
 - Dew: absent

After a longer period of storage or use, the tolerance can increase; but, according to standard specification, it may never exceed twice the value measured at the time of delivery.

Disclaimer

All our capacitors are designed, manufactured and tested to specifications. We strictly adhere to standards in procurement of materials, in the laid down manufacturing processes and consistently apply stringent process controls and testing parameters. This ensures that our capacitors always perform to the offered specifications.

Appropriateness of use in a specific circuit and fitness to a particular application however needs to be verified and its reliability through expected lifetime is required to be validated by the customer. Deki's responsibility is limited to ensuring that the capacitor performs as claimed in the specification/ data sheets provided by Deki. Deki specifically disclaims any implied warranties of fitness for any particular purpose. Liability, in any case is limited to the price paid for the capacitors.