

COMPONENT SPECIFICATION

SERIES NAME Metallized Polypropylene CDI Film
Capacitors
SERIES CODE 09



GIVEN BY: DEKI ELECTRONICS LTD

DEKI ELECTRONICS LTD

B-20, SECTOR-58, NOIDA 201301

Tel: +91 120 2585457/58 • Fax: +91 120 2585289 • Email: rd@dekielectronics.com

Metallized Polypropylene CDI Film Capacitors

Dip Type • Series Code 09

Part Number Description

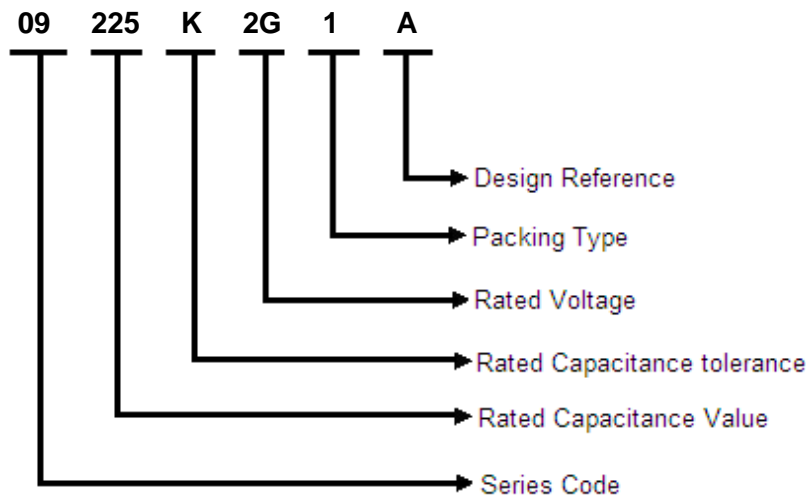

Rated Capacitance

Three-digit (225) indicate rated capacitance in Pico Farad (First two digits indicate value & third digit indicates number of zeroes to be suffixed to first two digits).

For example:

103 = 10 × 10 ³	= 10000 pF	= 10 nF	= 0.01 μF
104 = 10 × 10 ⁴	= 100000 pF	= 100 nF	= 0.1 μF
105 = 10 × 10 ⁵	= 1000000 pF	= 1000 nF	= 1 μF
106 = 10 × 10 ⁶	= 10000000 pF	= 10000 nF	= 10 μF

Capacitance Tolerance

In 3rd group of the part number-

F = ±1%, G = ±2%, H = ±2.5%, I = ±3.5%, J = ±5%, K = ±10%, L = ±15%, M = ±20%, N = ±40%

Rated Voltage

In 4th group of the part number, one numeric digit and one letter (Ex.-2A) indicate DC voltage rating while two numeric digits (Ex.03) indicate AC voltage rating.

Rated Voltage Codification

For DC Rated Voltage													
A		B		C		D		E		F		G	
1A	10	1B	12.5	1C	16	1D	20	1E	25	1F	30	1G	40
2A	100	2B	125	2C	160	2D	200	2E	250	2F	300	2G	400
3A	1000	3B	1250	3C	1600	3D	2000	3E	2500	3F	3000	3G	4000
H		I		J		K		L		M		N	
1H	50	1I	45	1J	63	1K	70	1L	80	1M	85	1N	90
2H	500	2I	450	2J	630	2K	700	2L	800	2M	850	2N	900
3H	5000	3I	4500	3J	6300	3K	7000	3L	8000	3M	8500	3N	9000
O		P		Q		R		S		U		V	
1O	110	1P	120	1Q	57.5	1R	15	1S	17	1U	130	1V	60
2O	1100	2P	1200	2Q	575	2R	150	2S	170	2U	1300	2V	600
3O	11000	3P	12000	3Q	5750	3R	1500	3S	1700	3U	13000	3V	6000
For AC Rated Voltage													
01	02	03	04	05	06	07	08	09	10	11	12	13	14
190	250	275	305	310	440	500	600	700	63	230	330	400	450
VAC	VAC	VAC	VAC	VAC	VAC	VAC	VAC	VAC	VAC	VAC	VAC	VAC	VAC

Metallized Polypropylene CDI Film Capacitors

Dip Type • Series Code 09

Packing Type

- 1: Bulk packing (original pitch)
- 2: Bulk packing (after forming & cutting)
- 3: Ammo packing (after forming & taping)
- 4: Bulk packing (after forming in original pitch without cut)
- 5: Bulk packing (after formed & without cut)
- 6: Ammo packing (Straight lead)
- 7: Bulk packing (Straight lead cut)
- 8: Reel packing (Straight lead)

Reference Data

Capacitance	1.0 μ F to 3.3 μ F
Capacitance Tolerance	\pm 5% to \pm 10%
Rated Voltage	400 Vdc
Permissible AC voltage at 50Hz/60Hz	200 Vac
Climatic testing class according to IEC 60068-1	40/85/56
Maximum application temperature	100°C
Rated temperature	85°C
Reference standards	IEC 60384-16
Dielectric	Polypropylene
Electrodes	Metallized
Construction	Mono
Encapsulation	Coated with flame retardant epoxy powder
Leads	Tinned wire

Marking on capacitor body

Type of capacitor, rated capacitance, rated tolerance, rated voltage and lot number will be available on each and every capacitor. Example- CDI MPP D155K2G/ Lot No.

Compatibility to RoHS



Dimensions Description

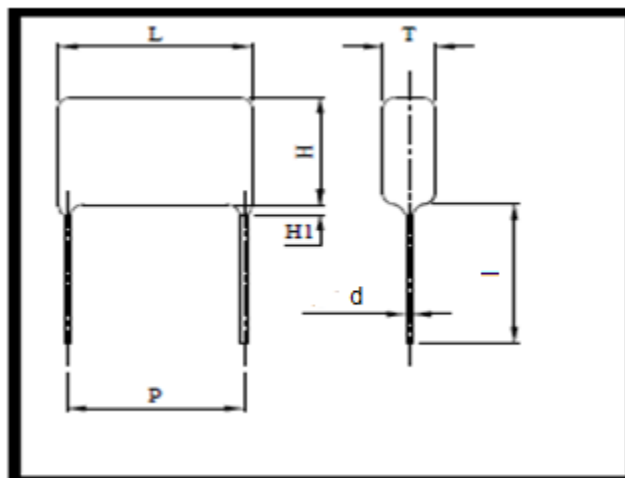

Metallized Polypropylene CDI Film Capacitors

Dip Type • Series Code 09

Rated Voltage	Rated Capacitance (μF)	Dimensions (mm)						dV/dt (V/μs)	Part Number
		L (Max)	H (Max)	T (Max)	P (mm)	d (±0.05)	l		
400Vdc/200Vac	1	31	19	8	27.5±1.0	0.8	17 Min.	100	09 105 K 2G 1 A
	1.5	31	20	10	27.5±1.0	0.8	17 Min.	100	09 155 K 2G 1 A
	1.5	31	19	10	27.5±1.0	0.8	17 Min.	100	09 155 K 2G 1 B
	2	31	23	13	27.5±1.0	0.8	17 Min.	100	09 205 K 2G 1 B
	2	31	23	13	27.5±1.0	0.8	17 Min.	100	09 205 K 2G 1 U
	2.2	31	22	11.5	27.5±1.0	0.8	17 Min.	100	09 225 K 2G 1 A
	2.2	31	23	13.5	27.5±1.0	0.8	17 Min.	100	09 225 K 2G 1 B
	3.3	31	27.5	17	27.5±1.0	0.8	17 Min.	100	09 335 K 2G 1 A

*H1 ≤ 2.0 MM

Specific Data

Description

Value

Maximum tangent of loss angle (Tanδ)	Frequency	$C_R \geq 1.0 \mu F$
	1 kHz	0.0008
	100 kHz	0.02

Voltage proof test between leads 1.6 times of the rated DC voltage for 2 second

Insulation Resistance (R_{IS}) Time constant
(or) time constant $T = C_R \times R_{IS} \geq 30000 \text{ sec}$

at 100 VDC at 20° C, relative humidity ≤70%

Temperature Derating Graph

For temperature between 85°C and 100°C a derating factor of 1.25% per °C on the rated voltage V_R has to be applied.

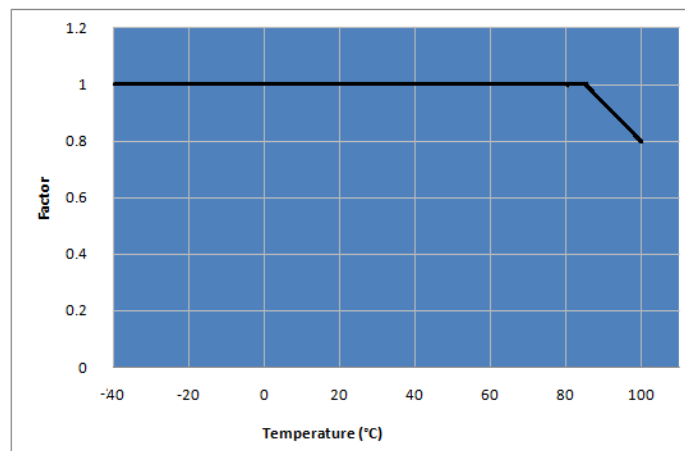

Power Dissipation and Maximum Component Temperature Rise

After applying the A.C voltage to the capacitor with certain frequency, we can measure the hot spot temperature of the capacitor. From that we can calculate ΔT .

ΔT = hot spot temperature – ambient temperature

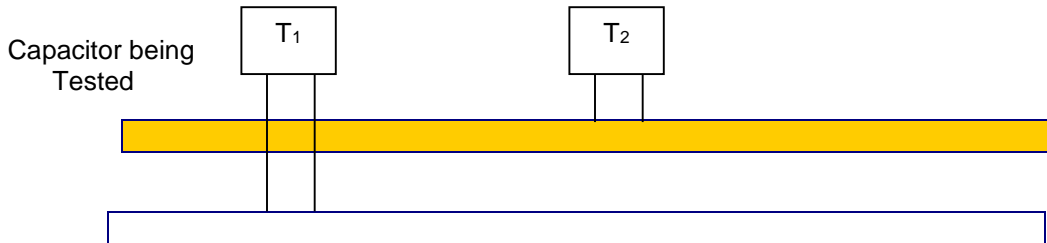

T₁ is the capacitor under test (Connected in the circuit)

T₂ is capacitor which has no connection

Distance between T₁ and T₂ should be about 50mm and 100mm from other components. To avoid radiation or convection, the capacitor should be tested in a wind-free box. The capacitor under test is separated by polystyrene.

$$\Delta T_{\max} = T_1 - T_2$$

at one frequency level the ΔT_{\max} reach 10°C. That is the frequency which we have to start frequency derating.

Storage Conditions

Avoid storing the capacitors in places where the environmental conditions differ from the following:

Storage time: ≤ 24 months from the date marked on the label glued to the package.

- Temperature: -40 to 80°C
- Humidity:

- Average per year: $\leq 70\%$
- For 30 full days randomly distributed throughout the year: $\leq 85\%$
- Dew: absent

After a longer period of storage or use, the tolerance can increase; but, according to standard specification, it may never exceed twice the value measured at the time of delivery.

Disclaimer

All our capacitors are designed, manufactured and tested to specifications. We strictly adhere to standards in procurement of materials, in the laid down manufacturing processes and consistently apply stringent process controls and testing parameters. This ensures that our capacitors always perform to the offered specifications.

Appropriateness of use in a specific circuit and fitness to a particular application however needs to be verified and its reliability through expected lifetime is required to be validated by the customer. Deki's responsibility is limited to ensuring that the capacitor performs as claimed in the specification/ data sheets provided by Deki. Deki specifically disclaims any implied warranties of fitness for any particular purpose. Liability, in any case is limited to the price paid for the capacitors.