

CHARGE

January 2021

A Technical News Journal from Deki Electronics Ltd

Editor's Desk

Dear Reader,

The year 2020 was an unforgettable year with Covid 19 paralysing the whole world and a total lockdown in India from March 24th. Deki reopened with 25% workforce from end-May with wearing of masks, sanitization and social distancing in place. By end-July we were working with the full workforce. Though it has been a very tough time for all of us, I think Covid-19 has taught us:

- 1) To make do with less
- 2) To spend more time with family
- 3) To work from home
- 4) To replace vendor/customer visits with video calls

The new year has brought good news of the vaccine roll out that has started on 16th January. Hopefully, this will improve the situation to a large extent and, though we will have to continue wearing masks and maintaining social distance, our immunity will be increased with the vaccine.

Now to business: The total AC market in India was approximately 7 million pieces in 2019 with year on year growth at over 10%. Thanks to the move towards energy saving the share of Inverter ACs is increasing. At Deki, we have developed a full range of film capacitors for both, the ODU (outer door unit) and IDU (indoor door unit) of these ACs. As a result this issue of Charge is devoted to film capacitors for Inverter ACs.

As always, we look forward to your suggestions to improve Charge further.

Anil Bali



NeoLync India is one of the sixteen companies to get approval under the Government of India's PLI scheme.

Approval Under Government of India's PLI Scheme to NeoLync India

NeoLync India is a joint-venture between NeoLync, an Israeli electronics company, and Deki Electronics. The company has been accorded approval under the Production Linked Incentive Scheme (PLI) for Large Scale Electronics Manufacturing.

With Neolync's technological knowledge and Deki's proven

track record in capacitor manufacturing, NeoLync India proposes to setup a large manufacturing facility to manufacture passive electronic components including but not limited to capacitors, resistors, inductors and Systems in Packages (SIPs).

NeoLync India will localise component manufacturing and would be important to support industries such as mobile phones, automotive, medical devices, solar energy clean energy products, etc., including Neolync's other manufacturing projects.

The Neolync team includes a core group of individuals from Israel, US and India, well experienced in navigating multiple cultural environments, developing and maintaining relationships with global brands, design and technology partners, with a mission to spearhead the development of the next India based global electronics manufacturing company.

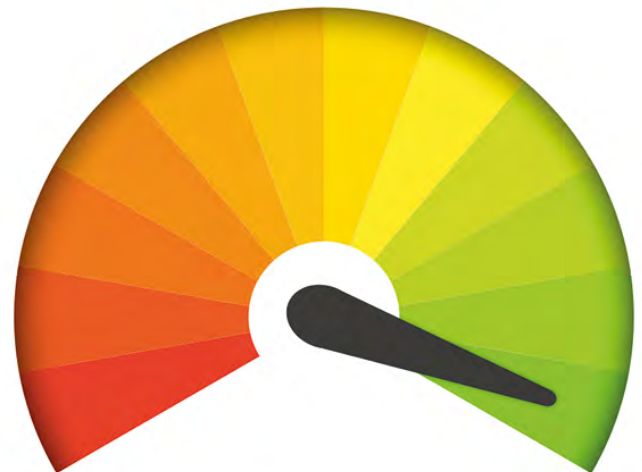

Back to Normalcy in Double Quick Time

At Deki, our manufacturing was back at pre-lockdown levels by the end of July 2020. And, we have to thank three sets of people for helping us get back to normalcy in double quick time.

First, we thank every member of Team Deki. They rose to the challenges posed by Covid-19 and worked hard, with all safety and security precautions, to ensure a smooth and orderly re-start and functioning of our manufacturing lines.

Second, we thank our suppliers and vendors who made certain that nothing came in the way of production, from raw material to finished goods right down to dispatch and delivery.

Thirdly, and finally, we thank our customers for keeping their faith in us and placing their orders and being patient while we got things going once again.

Without the support from all of you, our machines could not have been working at full speed so soon after the lifting of the lockdown.

Together, and with the requisite precautions, we can overcome the pandemic and get back to our normal lives. Sooner, rather than later.

For your FREE subscription, please contact Deki Electronics Ltd,
B-20 Sector 58, NOIDA 201 301. Phone +91 120 2585457, 2585458
Fax +91 120 2585289 E-mail bali@dekielectronics.com
www.dekielectronics.com

Inverters

An inverter is a power converter based on semiconductors. Basic function of an inverter is that it converts a direct current into an alternating current.

Basic block diagram for inverter is:

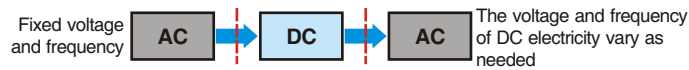

In 3-phase air conditioners an inverter is mainly used for speed control of 3-phase AC motor. For this there are two major speed control methods:

Rotation speed control of motor

For three-phase AC induction motor rotation speed or RPM of motor is inversely proportional to the number of poles (P) and proportional to frequency (f)

$$N(\text{rpm}) = 120 \frac{\text{Frequency (f)}}{\text{No. of pair of poles (P)}}$$

Since the number of poles are fixed in motor and an inverter is capable of dynamically changing the frequency, it is mostly opted for variable-speed motor control applications.

V/F control

Even though the method above is theoretically correct it has certain drawbacks unless both voltage and frequency are controlled.

1. During starting of motor at lower RPM, excessive current or inrush current might flow into the motor, causing mechanical damage and heating
2. Lower efficiency.

That is why variable-voltage variable-frequency (VVVF) inverters are preferred for speed control of a 3-phase motor.

In order to overcome the above drawback, it is necessary that the output voltage (V) increases linearly with output frequency (f).

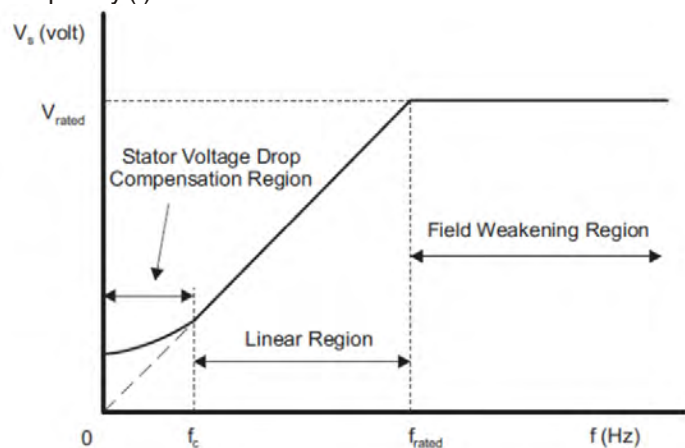

Classification of inverters

Inverters are classified into types based on output, source, type of load, etc.

Here is a complete classification of inverter circuits:

According to the Output Characteristic

1. Square Wave Inverter
2. Sine Wave Inverter
3. Modified Sine Wave Inverter

According to the Source of Inverter

1. Current Source Inverter
2. Voltage Source Inverter

According to the Type of Load

1. Single Phase Inverter
 - Half Bridge Inverter
 - Full Bridge Inverter
2. Three Phase Inverter
 - 180-degree mode
 - 120-degree mode

According to Different PWM Technique

1. Simple Pulse Width Modulation (SPWM)
2. Multiple Pulse Width Modulation (MPWM)
3. Sinusoidal Pulse Width Modulation (SPWM)
4. Modified sinusoidal Pulse Width Modulation (MSPWM)

According to Number of Output Level

1. Regular Two-Level Inverter
2. Multi-Level Inverter

System	Modulation	Commutation	Application example
Voltage-Type inverter	PWM	Sine-wave commutation (180° commutation)	Inverter air conditioner General-purpose inverter UPS Inverter household appliance Compressor
		Square-wave commutation (120° commutation)	Small fan motor Pump for water heater
	PFM		Power supply
	PAM		Inverter household appliance Pump
Current-Type inverter			Supersized inverter (DC power transmission)

PWM: Pulse Width Modulation • PFM: Pulse Frequency Modulation • PAM: Pulse Amplitude Modulation • UPS: Uninterruptible Power Supply

Modulation techniques

Basically, there are three modulation techniques to control the power supplied to the load

- **Pulse-width modulation (PWM):** modulation scheme in which the duty cycle is varied to control the output
- **Pulse-frequency modulation (PFM):** modulation scheme in which frequency is varied by varying number of pulses to control the output power. Also known as variable-frequency modulation (VFM)
- **Pulse-amplitude modulation (PAM):** modulation scheme in which the amplitudes of pulses are varied to control the output power.

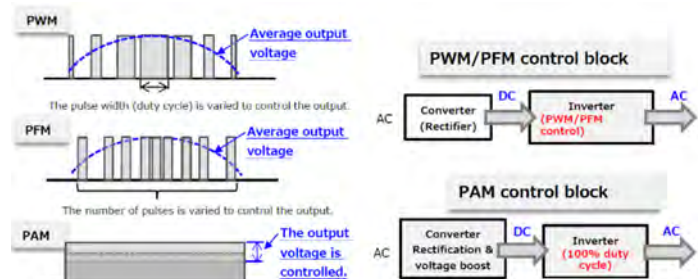

Modulation Techniques	Advantages	Disadvantages	Application Examples
PWM	Filter design is easy, due to fixed switching frequency.	Switching loss generates even in light load by fixed frequency.	Many motors use PWM control. The spread of brushless motors enlarges market of the PWM control.
PFM	Efficiency improvement is possible because of decreasing switching frequency at light load.	Filter design is difficult, due to frequency modulation.	PFM is mainly used for power supply rather than inverter equipment. PFM improves efficiency at no load to light load.
PAM	Efficiency and a power factor are good at wide range loads.	Parts count of switching circuit such as booster increases.	In home appliances with widely ranged load such as air conditioner and refrigerator, there are some application examples to improve the issue of their power dissipation at low load.

PWM and PAM control circuits

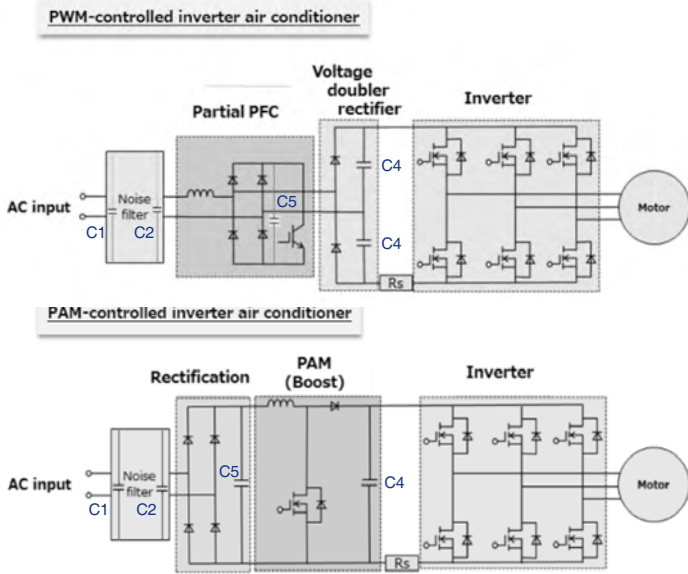

The Deki perspective

The above circuits show simplified diagrams for inverters for air conditioners. As a film capacitor manufacturer, we have different capacitors in the circuit for different purposes as per the list below:

Assumed location in PCB	Typical Cap Value Range	Purpose of the capacitor
ODU		
C1	1 μ F-3.3 μ F	EMI Suppression
C2	1 μ F-3.3 μ F	EMI Suppression
C3	0.1 μ F-0.33 μ F	Across BLDC fan for suppression
C4	0.47 μ F-1.5 μ F	After boost circuit for signal smoothing
C5	0.47 μ F-1.5 μ F	After bridge for signal smoothing
IDU		
C1	0.1 μ F-0.33 μ F	EMI Suppression
C2	0.1 μ F-0.33 μ F	EMI Suppression
C3	0.1 μ F-0.33 μ F	Across BLDC fan for suppression

For appropriate selection of the capacitor, we have done rigorous tests, including electrical stress test, capacitor, high voltage test and endurance test, etc. In the electrical stress across the capacitor we checked voltage and current developed on capacitor in real time situation as in an actual circuit. Here are the resultant waveforms:

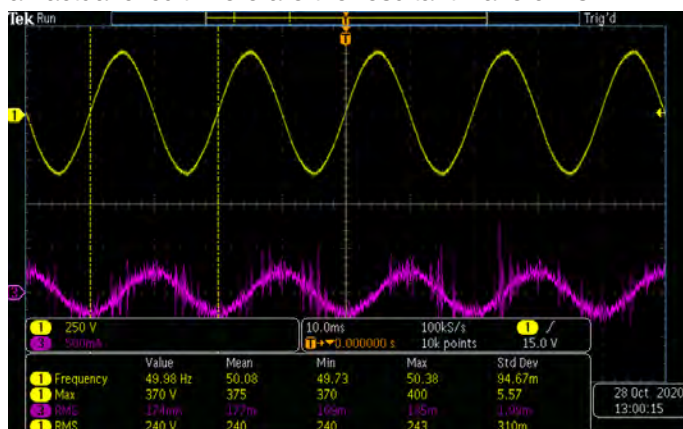

Electrical stress across X-2 capacitor at 240 VAC/50Hz

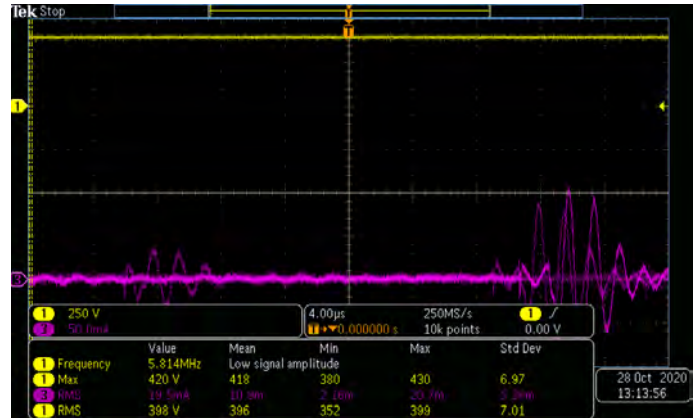

Electrical stress across capacitor used for suppression across BLDC fan at 240 Vac/50Hz during compressor on

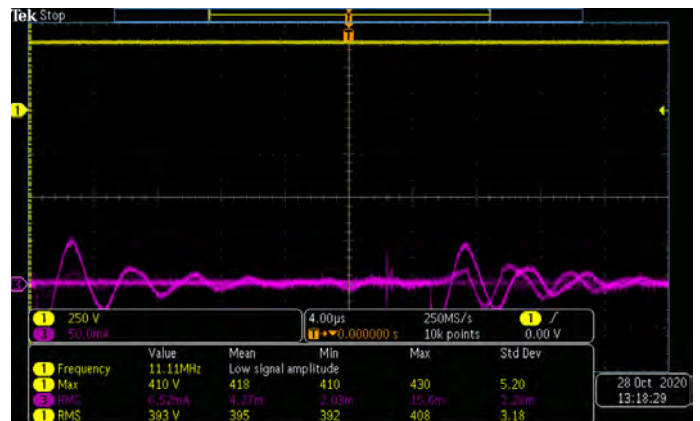

Electrical stress across capacitor used for signal smoothing after boost at 240 Vac/50Hz during compressor

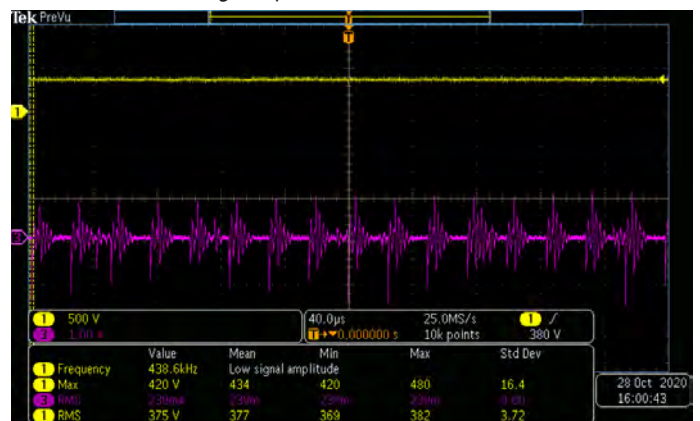

Electrical stress across capacitor used for signal smoothing after bridge at 240 Vac/50Hz during compressor on



We are Charging the Power Sector

Deki's customers include companies working in the power sector, especially:

- Welding Machines
- AC Inverter Circuits
- Industrial UPS
- Automatic Variable Drives
- Railway AC Control Panels

In their quest towards an Atmanirbhar Bharat our customers approached us to develop a full range of power capacitors.

Ever ready for a challenge and believers in Vocal for Local ourselves, we, at Deki, worked on this requirement and have come out with a comprehensive range of capacitors for the power sector. The range includes:

- Axial Capacitors - flat and round in metallised polyester and metallised polypropylene
- DC Link Capacitors - Leaded and lug type
- Snubber Capacitors - Leaded and lug type
- X2 Capacitors with UL/ENEC approval
- DC and AC Filter Capacitors

The power capacitor range has been a great success with customers. In addition to desired performance, Deki customers have not only cut lead times and reduced inventory cost but also saved on valuable foreign exchange.

We are grateful to our customers who believed in us and supported our efforts in developing the indigenous range of power capacitors.

Together, we shall indeed become Atmanirbhar Bharat!

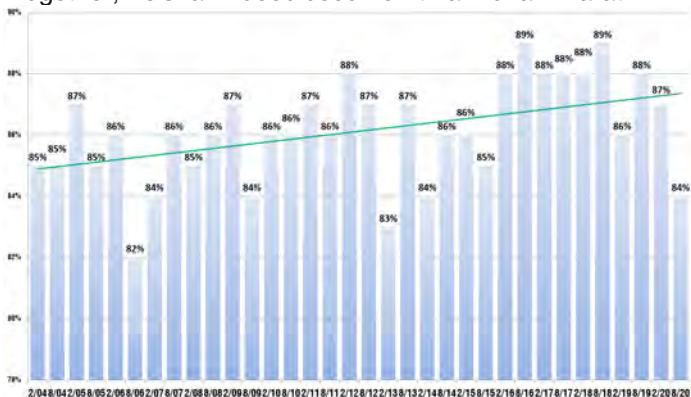

Employee Satisfaction Survey

Deki also conducts an employee satisfaction survey every six months in which all direct employees are asked fifteen questions pertaining to:

1. Their work environment
2. Salary
3. Satisfaction level
4. Growth opportunity

5. Knowledge of targets, standard specifications, operating procedures, etc.

Marks are accorded to each question and then consolidated into a report that compares the results of the most recent survey with the previous one. This consolidated report, along with the action points for improvement, are discussed with all the employees in an 'Open House' by Mr Vinod Sharma, our Managing Director. The August 2020 survey showed a more or less stable trend of 84-87%.

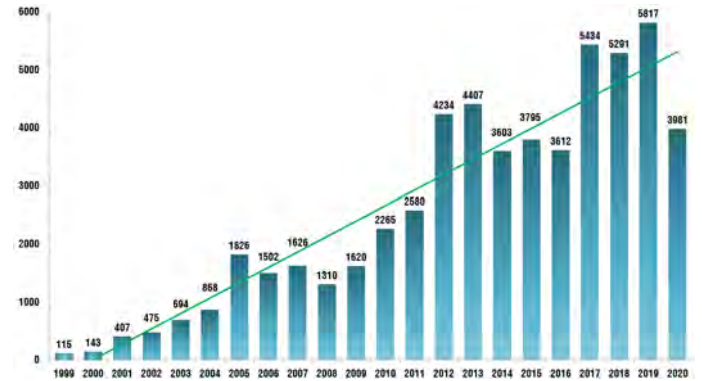

Training is Important at Deki

Training in Deki receives utmost importance and, as an integral part of continual skill enhancement, it has been growing consistently. Detailed stage wise training is being conducted in which knowledge of the process and the machines is being imparted followed by a written test. An employee has to score a minimum of 80% at critical stages to qualify to run the machine. Deki's training modules have been well recognised and serve as a benchmark for component manufacturers. Deki's spends more than 5% of the time on training. However, in the year 2020 training was affected on account of the Covid-19 pandemic.



External Customer Satisfaction Survey

Deki conducts an external customer satisfaction survey every six months and from the time we started this measurement in 2004 we have been showing consistent growth from an initial satisfaction rating of 75%. In the six months following each survey we act on the two points highlighted by our customers during the survey. Our customers recognise this effort of Deki and it is reflected in the score in the next survey.

In the recent survey covering July–December 2019 the Deki satisfaction score is 87%.